

KINETROL



EHD 1/4 Turn Electric Actuator

EHD 1/4 Turn Electric Actuators

A Hydraulic gear pump immersed in its own reservoir delivers pressurised oil to the vane-type 90° actuator via the control box, which contains non-return valves and solenoid valves to direct the flow into the actuator; with cam operated limit switches to control travel and (optionally) signal position to the user. The unpressurised side of the actuator is connected to the reservoir, so there is no net transfer of oil from reservoir to actuator. The pump and its motor run entirely on precision ball bearings, so that the friction and motor size can be minimised and life maximised; the efficiency resulting from this reduces the heating effect and allows 100% rating. A pressure release valve is built into the pump so that if the actuator load becomes jammed the torque is limited and dangerous over pressures or motor stalls are avoided.

Fail-safe spring return action uses a reliable low-stress-range sealed clock-type spring unit mounted coaxially with the actuator, together with a fail-open solenoid valve, to ensure reliable positioning when power is not supplied to the unit. A high flow external dump valve can be fitted to allow very rapid spring-driven action (to be wired by customer - contact Kinetrol for details).

Double-acting models are supplied with solenoids arranged to give position locking when power is disconnected. An optional manual by-pass valve is available to allow manual override movement of a double acting when power is disconnected.

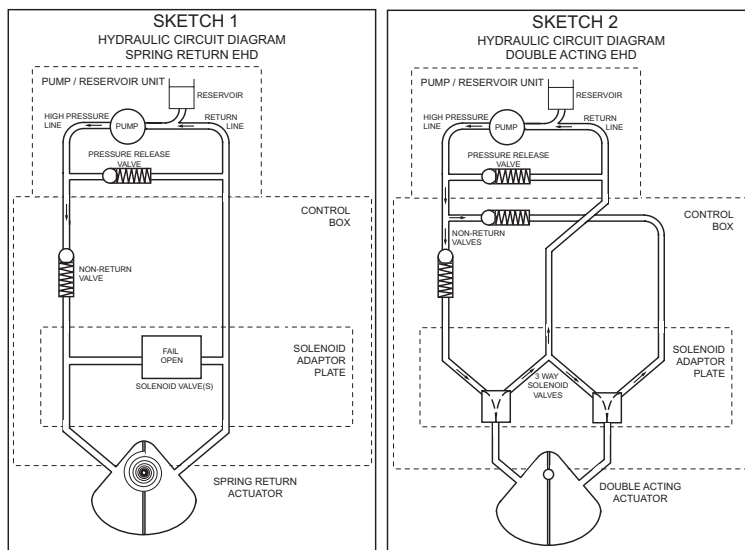

The interface between pump/reservoir unit and the control box allows mounting of the pump in different orientations at 90° to each other, so that the motor can be kept above the reservoir whether the actuator output axis is horizontal or vertical. External electrical connections are all made via a single accessible connector block in the control box, with the simplest possible switching needed to drive the unit. Two conduit entries are available, to allow easy separate connection of power and signal lines (if used). All internal wiring is connected via a central connector and fuse board, and the actuator is protected from supply surges by a metal oxide varistor suppressor.

PUMP MOTOR - Brushless, runs on ball bearings for unlimited maintenance free life. AC types are single phase capacitor induction motors, with self-resetting cut-out for over temperature protection. DC type is brushless with integral drive circuitry.

OIL PUMP WITH INTEGRAL RESERVOIR - Efficient low friction gear pump runs on ball bearings for minimum wear, maximum life. Enclosure integrates pressure release valve to prevent harmful overpressure build up. Uses silicone oil for minimal effect of temperature on performance.

OPTIONAL ANGLE ADAPTOR PLATES - Whilst the standard orientation is a vertical mount, horizontal mounts are possible without the circular adaptor plate. However an angular adaptor plate is available to allow mounting of the motor-pump within 15° of vertical whatever the angle at which the actuator output shaft is mounted.

MULTI-POSITION PUMP MOUNTING INTERFACE - Allows motor to always be above oil reservoir, so that motor shaft seal is never pressurised by oil and motor always remains free of oil.

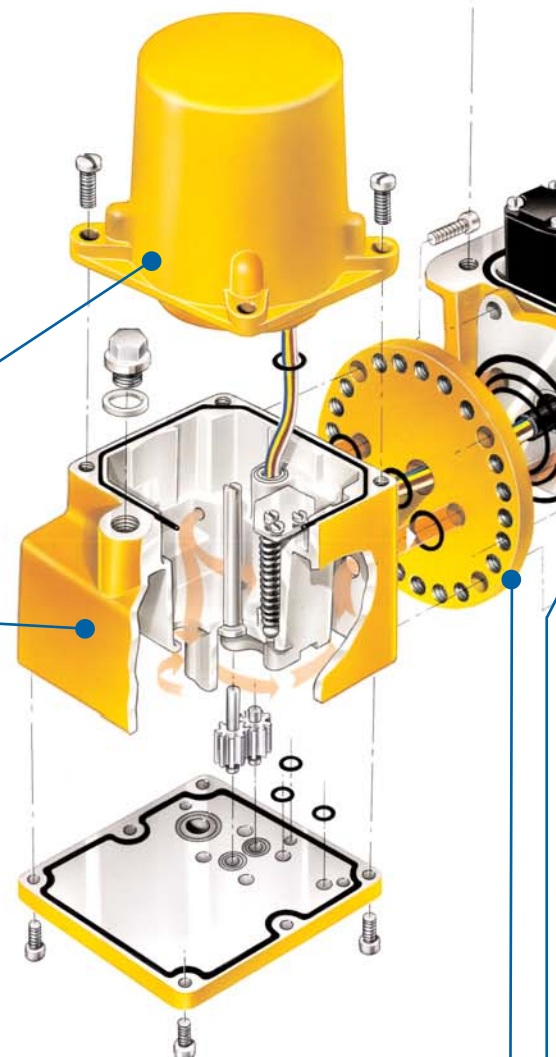

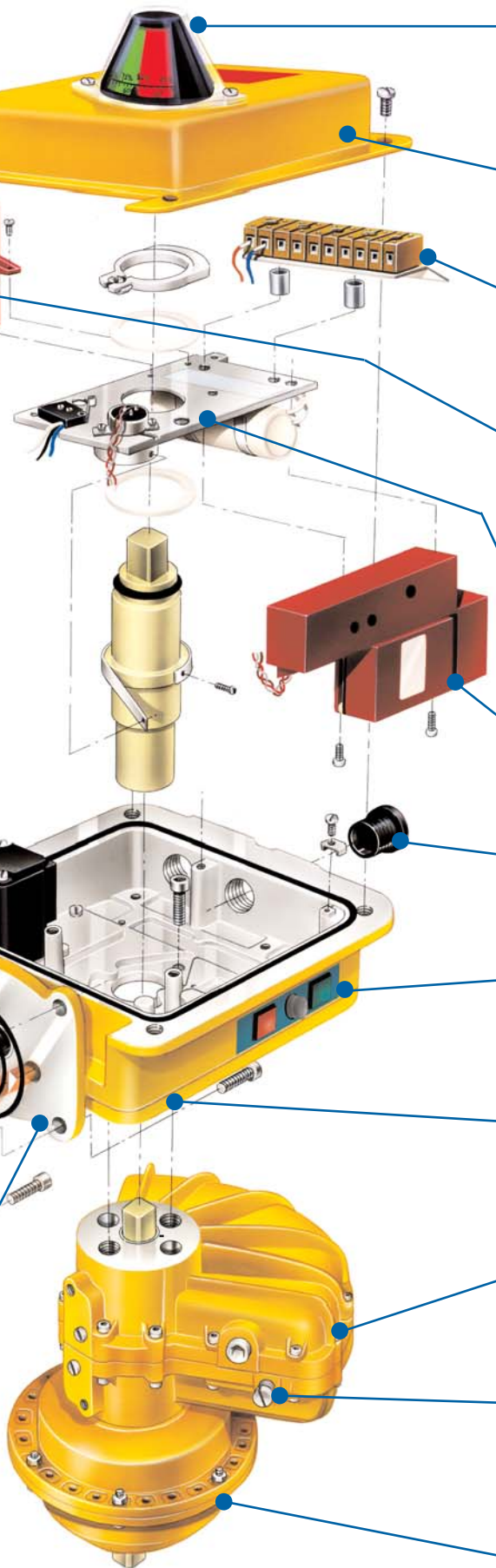

CLEAR CONE MONITOR - Externally visible position indication shows open-closed status and/or angular position through full 180° viewing angle - made of robust transparent polymer fully sealed onto metal lid. A special option for chemical resistance is available.

LID - Made of robust epoxy-coated zinc alloy, held on by captive screws and sealed with nitrile rubber O-ring.

CONNECTOR BLOCK FOR EXTERNAL WIRING - Easy access 10 way block for cables up to 2.5mm². Connects all power and signal cables needed.

FUSE & CONNECTOR BOARD - Easy access fuses and integral over-voltage detectors protect against over-voltage damage to major components. Easy access connector block allows rapid disconnection of motor and solenoids for maintenance or inspection.

CARRIER PLATE - All connectors, limit switches, motor capacities, positioner modules and other optional electronic units are mounted on this easily removable plate for easy examination and access.

POSITIONER CIRCUIT - Optional electronic 4-20 mA positioner - see overleaf for details.

CONDUIT PLUG - If only one of the conduit entries is needed by the user, the plug gives permanent sealing to the unused entry, while remaining removable if necessary.

LOCAL ISOLATION SWITCHES - This option allows the user to switch between local and remote control, with CW and ACW switches available on unit.

CONTROL BOX - All metal assembly integrates oil parting, non-return valves, mounting for solenoid valves, shaft sealing and mounting arrangement onto actuator. Encloses all central electrical wiring inside robust box, sealed by O-rings to IP 65 / NEMA 4, with tough epoxy enamel finish for external protection.

KINETROL VANE ACTUATOR - Compact, robust long life design with one moving part gives optimum efficiency and reliability in converting oil pressure into output torque.

ADJUSTABLE END STOPS - Easy adjustment at each end of stroke for accurate seating.

FAIL SAFE SPRING UNIT - Fully sealed clock type spring unit, operating over small range of stress gives best reliability and most constant torque output available. Fail-safe action requiring no maintenance, no batteries and no gas bottles. Male or female output drives available.

EHD Positioner

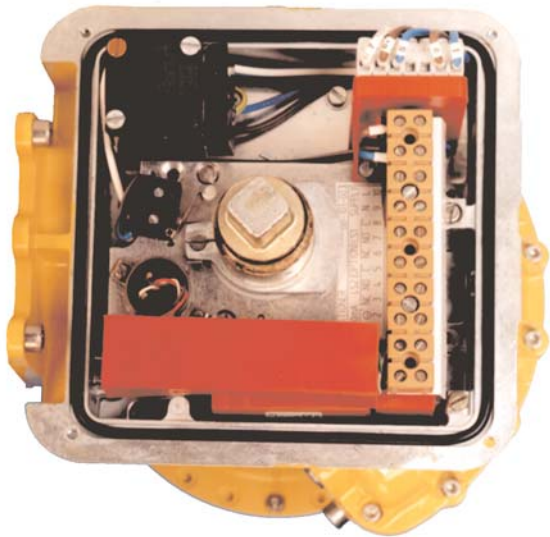

- Moves to and holds any position between 0° and 90° in response to control signal (4-20mA standard, split range available).
- Integral with standard actuator - no add-on modules.
- Excellent sensitivity, linearity, accuracy and stability.
- Available with fail-safe and double-acting actuators.
- Adjustable range, zero and dead bank.
- Economical simple installation - only one connector block.
- Suitable for oscillating and unstable loads.

Positioner Specification

An electronic circuit and a feedback potentiometer are fitted inside the standard actuator control box. The circuit is a high stability linear comparator, which switches the actuator pump and solenoid valves via solid state mains switches in response to the difference between the actual position measured by the potentiometer and the intended position given by the 4-20mA signal. Limit switches prevent the actuator driving against its own endstop, whatever the signal may be.

The positioner mains switches are optically isolated from the low voltage DC control circuit, which is electrically isolated from the rest of the actuator.

The feedback potentiometer is a conductive plastic servo-type unit driven by a backlash-free drive. The positioner circuit is mounted inside an insulating polymer box for safety; it is fitted with screwdriver adjustable potentiometers to allow customer turning of zero, gain and dead band width.

The efficient design of the Kinetrol EHD actuator allows a high start frequency to be achieved, without overheating. The positioner is available on fail-safe spring-return and double-acting units, and gives accurate, linear low hysteresis performance with excellent thermal stability. The intrinsic stiffness of the hydraulic system together with the backlash-free design of the Kinetrol vane actuator makes this positioner very tolerant of varying or unstable loads (eg . butterfly valves). The complete absence of separately mounted enclosures makes installation neat, simple and economical - all external connections for power, signal and limit switches are made to the normal connector block in the control box.

Control response:	0° to 90° positioning, linearly proportional to 4-20 mA control signal (factory set) (4-20mA and 12-20mA versions are available).	
Range:	Preset pot adjustable to vary angular range by at least ± 15%.	
Dead Band:	Preset pot adjustable to give dead band 0.1° to 1.6° of travel.	
Sensitivity*:	14, 12 and 09 models	<0.04mA
	07 model	<0.06mA
	05 model	<0.15mA
Hysteresis*:	<0.5% of span	
Repeatability:	<0.5% of span	
Deviation from linearity:	<1% of span	
Operating temperature range:	-20°C to +60°C (-4°F to 140°F) (contact Kinetrol for low temperature options).	
Setpoint stability across operating temperature range:	Drive <0.5% of span	
Maximum number of starts per hour:	3,000	
Supply Voltage:	240VAC, 115VAC, 24VDC and 24VAC. 50/60 Hz	
Control input resistance:	250 ohms for 4-20mA signal 500 ohms for 4-12mA and 12-20mA signals	
Max. power consumption:	150W	

*These parameters will achieve quoted levels only if the dead band adjustment is optimised by the user in accordance with the instructions supplied with this unit.

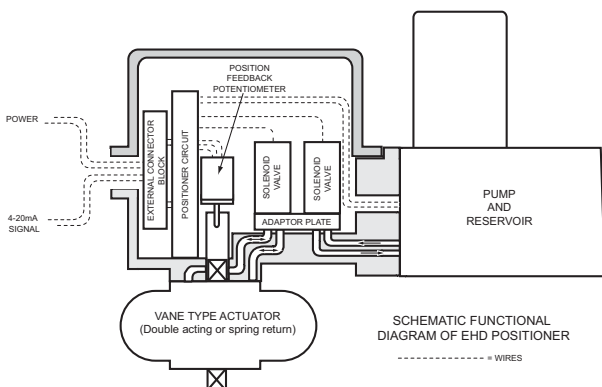



- ❑ FAIL SAFE uses simple integral spring unit working against electrohydraulic vane actuator - no batteries or gas bottles.
- ❑ DOUBLE ACTING also available for high torque conventional electric actuator options.
- ❑ INTEGRAL POSITIONER option drives to and holds any angle from 0° to 90° in response to 4-20mA signal.
- ❑ LOW WEAR from low-stress, low pressure gear pump driving simple vane actuator gives long life.
- ❑ RUNS ALL DAY and all night without overheating.
- ❑ IF LOAD JAMS, pressure release valve prevents overtorque or motor stalling.
- ❑ COMPACT POWERFUL SINGLE UNIT with no external pipes or wires.
- ❑ 6 MODELS - WIDE TORQUE/SPEED RANGE - each model can be specified as failsafe spring-return or high-torque double acting, on-off or modulating.
- ❑ ENVIRONMENTALLY SEALED ENCLOSURE to IP65/NEMA 4, with tough epoxy paint on robust cast metal to resist outdoor environments.

- ❑ AUXILIARY LIMIT SWITCHES optionally available for external signalling of position by user.
- ❑ FAIL LOCKED DOUBLE ACTING - Solenoid arrangement gives position locking on power disconnection - manual bypass valve can be fitted for manual override of fail-locked actuator.

Options

- ❑ LOCAL ISOLATION SWITCHES OPTION - Switch between local and remote control, with CW and ACW switches available on unit.
- ❑ LOW TEMPERATURE OPTION - A heater and jacket assembly can now be supplied to further increase our EHD operating temperature range.
- ❑ SILICONE FREE OIL VERSIONS AVAILABLE - A mineral oil is used instead of the standard silicone oil (temperature restrictions apply).
- ❑ INTEGRAL OPTIONS AND ADD-ON UNITS:
 - 4-20mA transducer for independent position feedback.
 - internal feedback potentiometer for connection to user's external circuit.
 - split range positioner signals (4-20mA and 12-20mA signals).
- ❑ CLASS 1 DIVISION 2 - FM hazardous environment approval is available for US/ANSI spring-return on/off models. (AC 15V AC only).
- ❑ CLEAR CONE - High visibility monitor available.
- ❑ ISO/DIN FEMALE DRIVE OPTIONS AVAILABLE

On-Off Specification

Power Consumption:	150W. Current AC Models 1.5A max. DC Models 6A max.
Supply Voltages:	230V or 115V ± 10%. 50 or 60 Hz AC, 24V DC and 24V AC.
Operating Temperature Range:	-20 to +60°C (-4 to 140°F) (contact Kinetrol for low temperature options).
Motor Type:	AC - permanent capacitor single phase induction motor running on sealed-for-life ball bearings. No brushes. Self re-setting thermal cut out built into windings. DC - Brushless with integral drive circuitry. Ball bearings.
Environmental sealing:	To IP65 / NEMA 4X
Auxiliary Limit switches:	User adjustable cams, 3 pole changeover type. 3A 250V Max
Position Indicator:	Red plastic indicator clamped onto control box square supplied as standard, clear cone and chemical resistant clear cone monitor options are available. Positioner models are complete with with indicator angle scale. No indicator is available if angle transducer is fitted.
Manual Override:	Declutchable geared units available for models 05 to 14. For model 05, levers are available for direct fitting to control box square.
Construction:	Hydraulic pump and control box - diecast zinc alloy Actuator Case - ZL 16 zinc alloy. Vane - 05 model stainless steel, others SG Iron. Spring return case - models 05,07,09 and 10 are die cast zinc alloy to BS 1004, models 12 and 14 cast LM25 aluminium alloy. Clock type spring - Carbon Steel External surfaces coated with tough, corrosion resistant epoxy paint.

Dimensions

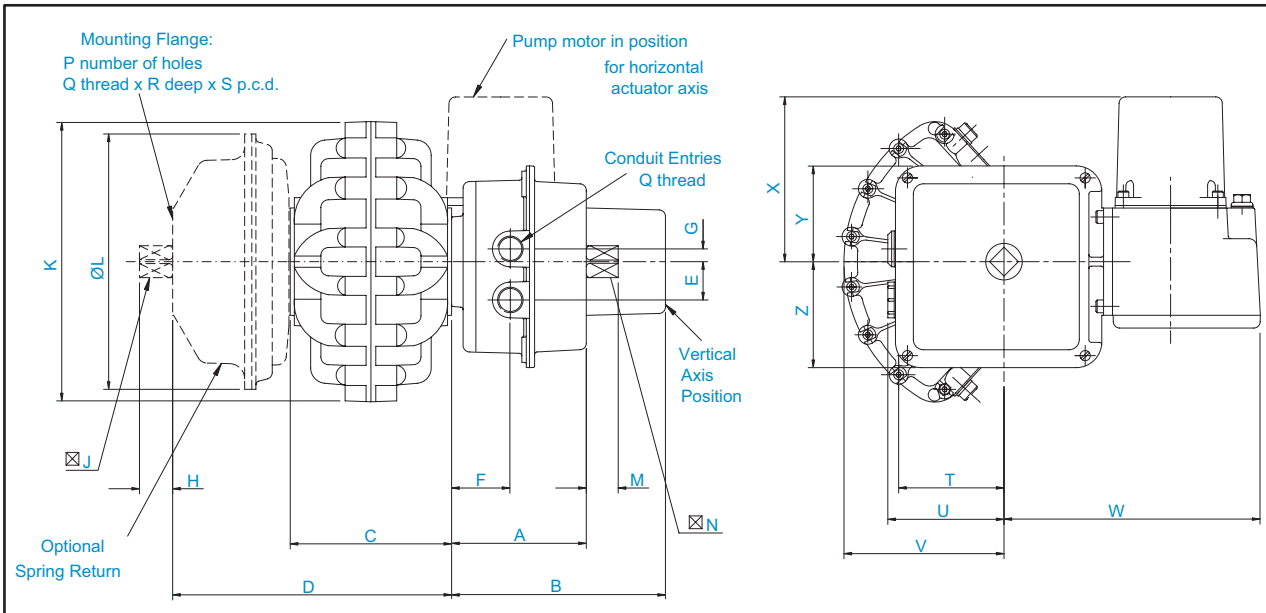

* 4900 Spring Units
Weights include oil
Add 0.2 kg (0.4lb) for positioner
Conduit entry thread 0: ISO - M20X1,5 DIN - PG 13,5 ANSI - 1/2"-14 NPS
*1 Loaded travel time at 20°C Multiply by 1.3 for DA models
*2 For model 10 only main table shows SR interface details only. DA details are female:

	H Deep	J
ISO/DIN	24	22
ANSI	0.94	0.87

ISO/DIN (METRIC) DIMENSIONS AND PERFORMANCE PARAMETERS

ACTUATOR MODEL	A	B	C	D	E	F	G	H	J	K	L	M	N	P	Q	R	S	T	U	V	W	X	Y	Z	Torque (Nm)		Travel Time (secs)	Travel Time With Optional Dump Valve (secs) ^{*2}	Weight (Kg)		
	(mm)	(mm)	(mm)	(mm)	(mm)	(mm)	(mm)	(mm)	(mm)	(mm)	(mm)	(mm)	(mm)	(No)	Thread	(mm)	(mm)	(mm)	(mm)	(mm)	(mm)	(mm)	(mm)	(mm)	SR	DA			SR	DA	
050/058	105	167	67	114	30	46	10	13	9.5	136	108	20	16	6	M5	8	34.9	85	87	79	201	129	75	83	20.9	17.5	44	7	1.5	12.3	11.0
070/078	105	167	100	182	30	46	10	20	16	178	152	20	16	4	M8	16	50.9	85	87	102.6	201	129	75	83	50.8	42.4	108	18	1.5	17.2	13.2
090/098	105	167	126	218	30	46	10	26	19	227	1200	20	16	4	M10	20	65	85	87	132	201	129	75	83	104	94	228	38	1.5	25.2	16.9
101/108	105	167	170	285	30	46	10	26 ^{*3}	22 ^{*3}	230	206	20	16	8	M10	20	102	85	87	130.5	201	129	75	83	164	143	371	60	2.0	32.0	20.5
120/128	105	167	171	308	30	46	10	31	25	294	258	20	16	4	M12	22	77.8	85	87	171	201	129	75	83	1238	204	506	83	2.5	39.1	23.6
140/148	105	167	218	435*	30	46	10	38	28.6	353	258*	20	16	4	M16	28.5	98.8	85	87	223	201	129	75	83	530*	445*	1220	194	7.0	63.2*	34.1

ANSI (ENGLISH) DIMENSIONS AND PERFORMANCE PARAMETERS

ACTUATOR MODEL	A	B	C	D	E	F	G	H	J	K	L	M	N	P	Q	R	S	T	U	V	W	X	Y	Z	Torque (lbf.in)		Travel Time (secs)	Travel Time With Optional Dump Valve (secs) ^{*2}	Weight (lb)		
	(in)	(in)	(in)	(in)	(in)	(in)	(in)	(in)	(in)	(in)	(in)	(in)	(in)	(No)	Thread	(in)	(in)	(in)	(in)	(in)	(in)	(in)	(in)	(in)	SR	DA			SR	DA	
059	4.13	6.58	2.64	4.49	1.18	1.81	0.39	0.51	0.375	5.35	4.25	0.79	0.63	6	10-24 UNC	0.32	1.375	3.35	3.43	3.11	7.92	5.08	2.95	3.27	185	155	390	7	1.5	27.1	24.2
079	4.13	6.58	3.94	7.17	1.18	1.81	0.39	0.79	0.63	7.01	6.00	0.79	0.63	4	5/16-18 UNC	0.63	2.00	3.35	3.43	4.04	7.92	5.08	2.95	3.27	450	375	955	18	1.5	37.8	29.0
099	4.13	6.58	4.96	8.58	1.18	1.81	0.39	1.02	0.75	8.94	7.87	0.79	0.63	4	3/8-16 UNC	0.79	2.56	3.35	3.43	5.19	7.92	5.08	2.95	3.27	925	830	2020	38	1.5	55.4	37.2
109	4.13	6.58	6.69	11.22	1.18	1.81	0.39	1.02 ^{*3}	0.866 ^{*3}	9.06	8.11	0.79	0.63	8	3/8-16 UNC	0.63	4.02	3.35	3.43	5.14	7.92	5.08	2.95	3.27	1450	1270	3250	60	2.0	70.4	45.1
129	4.13	6.58	6.73	12.10	1.18	1.81	0.39	1.22	0.98	11.57	10.16	0.79	0.63	4	1/2-13 UNC	0.87	3.06	3.35	3.43	6.73	7.92	5.08	2.95	3.27	2110	1810	4478	83	2.5	86.0	51.9
149	4.13	6.58	8.58	17.12*	1.18	1.81	0.39	1.50	1.13	13.90	10.16*	0.79	0.63	4	5/8-11 UNC	1.12	3.89	3.35	3.43	8.78	7.92	5.08	2.95	3.27	4680*	3960*	10800	194	7.0	139.2*	75.0

For female drive spring dimensions see Kinetrol literature KF 440

Ordering Codes

Two standard pump orientations are available (see drawing above). Consult Kinetrol if other arrangements are required. All units will be supplied with vertical axis actuators unless otherwise specified.

There are numerous options available for the EHD unit. For any of the below, contact Kinetrol for information on how to order:

- Slower speeds than those listed above
- Angle adjuster plates
- Low temperature units
- Silicone free oil units
- FM approved units
- Local isolation switches

The policy of Kinetrol is one of continuous improvement. We reserve the right to alter the product as described and illustrated without notice. For confirmation of the current specification, contact Kinetrol Limited.

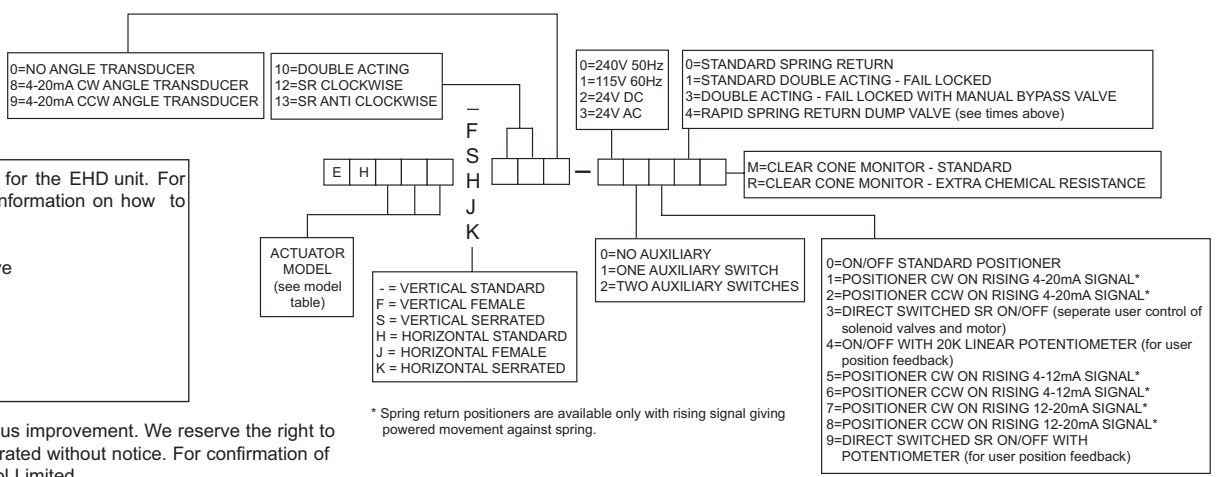

Kinetrol Ltd, Trading Estate, Farnham, Surrey. GU9 9NU, England.

Tel: 01252 733838 Fax: 01252 713042

E-mail: sales@kinetrol.com Web Site: www.kinetrol.com