

SC-3 Piece

ASME 2500 Class

In Stock — Available For Immediate Delivery

Applications

- Sootblower header
- Hot reheat spray
- Superheater spray
- Main turbine drain valve
- Boiler feed pump
- Main steam supply
- Main boiler drain
- Booster pump isolation

End Connections

- Buttweld
- Socketweld¹
- Flanged¹
- Clamped¹

Sizes

- 2 to 6 inch
- Stocked with 2 inch bore

¹ Available Upon Request

Features

In-line Repairability

- Three-piece valve assembly
- Valve body can be easily removed while end connections remain in-line
- Allows valve body to be tested after repair, prior to insertion back in-line

Ball & Seats

- Mate-lapped for 100% sealing contact
- Ensures absolute shutoff
- Corrosion resistant
- Seats are protected from flow in open / closed position
- Seats are field replaceable

Seat Spring

- Assisted by line pressure, provides a constant mechanical force on ball against seat to maintain seal

Body Gaskets

- Two proprietary body joint seals of Inconel 718
- Gold plating of gaskets creates a metallic permatext to assist in sealing
- Lowers contact stresses
- Ensures zero body leaks

Quarter-turn, Non-rising Stem

- Live loading
- Quick open / close operation
- Extends the packing life

Bill of Materials

Item No.	Description	Material
1	Ball	410SS / HVOF-CC Coated
2	Seat	410SS / HVOF-CC Coated
3	Spring	Inconel 718
4	Body	A182 F22
5	Gasket	Inconel 718 Gold Plated
6	Stem	A638 GR660
7	Inner Stem Seal	410 / CC Coated
8	Live Loading	Inconel 718
9	Gland Thruster	316SS
10	Gland Flange	410SS
11	Stem Packing	Expanded Graphite
12	Anti-Extrusion Rings	Braided Graphite w/ Inconel Wires
13	Nut	A194 GR4
14	Access Plug	A182 F22

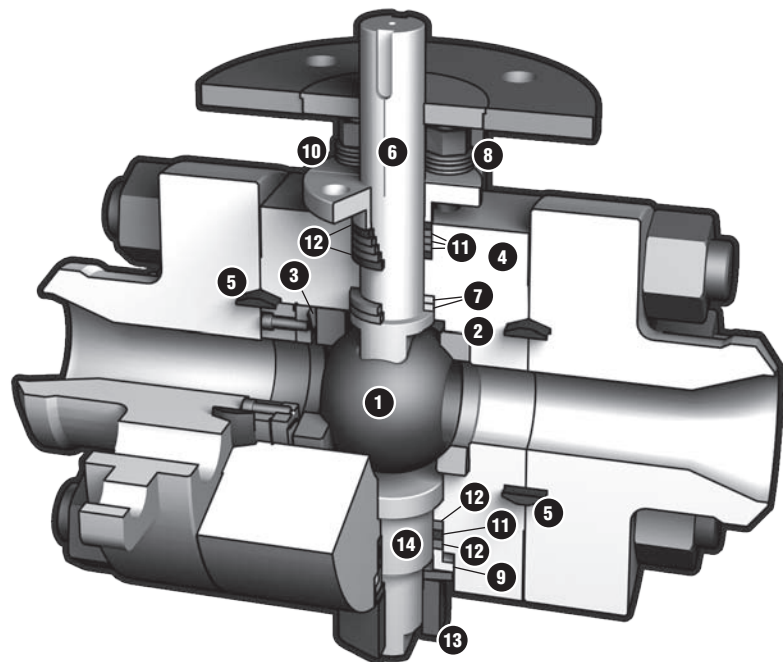

Flexibility of In-line Repair

Dimensions (in)						
Valve Size	Bore	A	B	C	D	Weight
2	2	10.00	20.00	2.38	7.31	259 lb
2-1/2	2	10.00	20.00	2.88	7.31	259 lb
3	2	11.38	22.75	3.50	7.31	265 lb
4	2	13.25	26.50	4.50	7.31	273 lb
6	2	18.00	36.00	6.63	7.31	310 lb

Dimensions (mm)						
DN	Bore	A	B	C	D	Weight
60	51	254	508	60	186	117 Kg
65	51	254	508	73	186	117 Kg
80	51	289	578	89	186	120 Kg
100	51	337	673	114	186	123 Kg
150	51	457	914	168	186	140 Kg

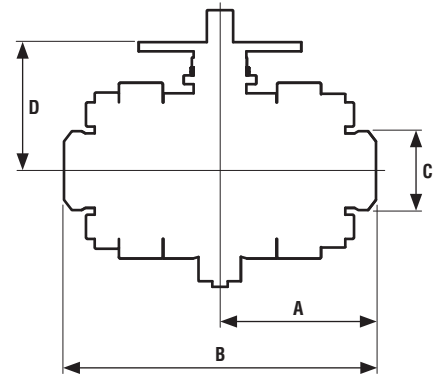

Bore (inches)	Pipe Size (inches) / Schedule									
	2 Sch 160	2 Sch XXS	2-1/2 Sch 160	2-1/2 Sch XXS	3 Sch 160	3 Sch XXS	4 Sch 160	4 Sch XXS	6 Sch 160	6 Sch XXS
2.00	186	148	295	228	210	285	152	164	124	126

Temperature vs Pressure — Standard Class Ratings																	
Class	Mat'l.	Temperature (°F)															
		-20 to 100	200	300	400	500	600	650	700	750	800	850	900	950	1000	1050	1100
ASME 2500 Maximum Pressure (psig)	F22 ²	6250	6250	6070	5880	5540	5040	4905	4730	4430	4230	4060	3745	3220	2230	1455	915

Class	Mat'l.	Temperature (°C)																		
		-29 to 38	50	100	150	200	250	300	325	350	375	400	425	450	475	500	538	550	575	600
ASME 2500 Maximum Pressure (barg)	F22 ²	431	431	429	418	405	386	357	344	335	323	305	292	282	264	235	154	130	88	57

²F22 not recommended for prolonged use above 1100°F / 593°C per ASME B16.34.

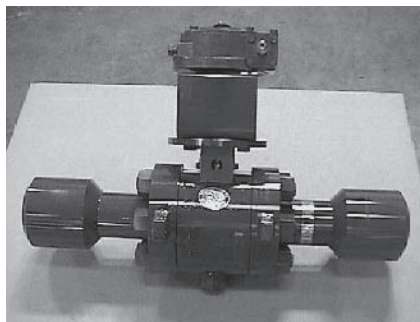

MOGAS was able to meet the customer's special requirements for unique fabricated end connections and specific top works.