

Applications

Overpressure relief of boiler/
superheater header

End Connections

Per customer specification

Sizes

2-1/2 to 4 inch

Standard Components

MOGAS ball valve
Actuator
Four-way electrically operated
solenoid valve
Control box
Limit switch

Optional Components

Pressure switch
Siphon tube
Air reservoir kit

Features

- ASME "V" stamp available
- Live loading ensures zero emissions from stem packing in the most severe temperature shocks
- High nickel alloy base ball and seat with a proprietary coating ensures superior wear resistance
- Quick operating pneumatic actuator decreases wear on sealing surfaces
- Field repairable

Bill of Materials

Item No.	Description	Material
1	Ball	Inconel 718 / Proprietary Coating
2	Seat	Inconel 718 / Proprietary Coating
3	Spring	Inconel 718
4	Body	A182 F22
5	Body Gasket	Inconel 718 Gold Plated
6	Stem	A638 GR660
7	Stem Bushing	431SS / Melonite and Xylan Coated
8	Live Loading	Inconel 718
9	Thrust Bearing	431SS / Melonite and Xylan Coated
10	Gland Flange	431SS / Moly Coated
11	Stem Packing	Expanded Graphite
12	Anti-Extrusion	Braided Graphite w/ Inconel Wires
13	Pusher Seat	431SS / Nitrided
14	Actuator	Pneumatic
	Solenoid Valve	Versa
	Limit Switch	Westlock
	Control Box	Model 307

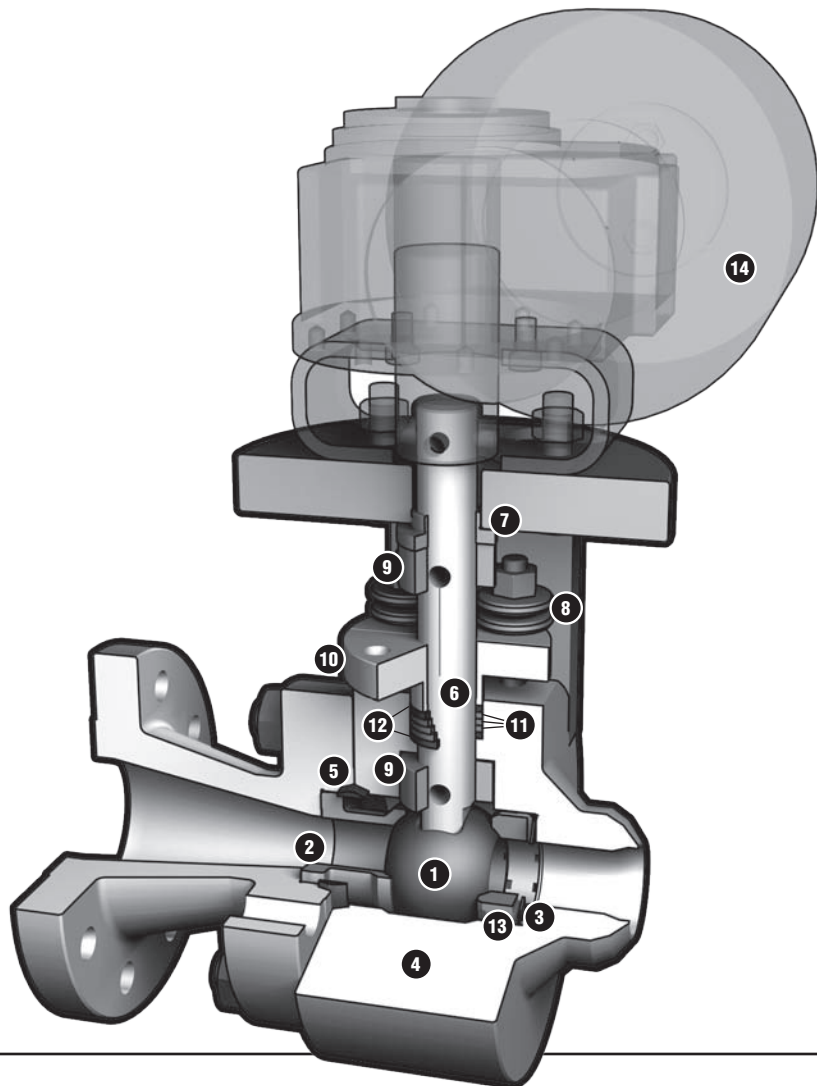

Prevents Excessive Pressure Build-up

High Performance Valve Contributes to Plant Safety

The MOGAS PORV, a pneumatic actuated pressure relieving valve, prevents excessive system pressure accumulation. The set pressure of the PORV is lower than that of the spring loaded safety valve to prevent or reduce the number of lifts of the safety valve, thus extending their life. The PORV is available either non-stamped or with the “V” stamp. The “V” stamped PORV has been flow certified by the National Board of Boiler and Pressure Vessel Inspectors.

The PORV operates as a system. The MOGAS ball valve is normally closed. The pressure switch senses steam pressure and closes an electrical switch when the pressure exceeds a predetermined point. This in turn energizes the solenoid valve, which pressurizes the “to open” cylinder port of the pneumatic actuator, opening the ball valve. When the pressure switch senses that the steam pressure has returned to normal, the electrical switch within the pressure switch opens, de-energizing the solenoid valve and closes the MOGAS ball valve.



Dimensions (in)						
Model	Bore ¹	Standard Class	A	B	C	Weight w/o Actuator
PORV-UD	1.60	1500 / 2500	4.35	12.88	7.00	115 lb
	1.60	4500	6.00	17.00	10.58	115 lb
PORV-UK	1.81	1500 / 2500	7.00	15.38	10.67	250 lb
	1.81	4500	6.00	20.00	11.06	250 lb
PORV-UM	2.00	1500 / 2500	5.38	14.55	10.75	200 lb
	2.00	4500	6.50	19.97	11.83	200 lb

Dimensions (mm)						
Model	Bore ¹	Standard Class	A	B	C	Weight w/o Actuator
PORV-UD	43	1500 / 2500	110	327	178	52 Kg
	43	4500	152	432	269	52 Kg
PORV-UK	46	1500 / 2500	178	391	271	113 Kg
	46	4500	152	508	281	113 Kg
PORV-UM	50	1500 / 2500	137	370	254	90 Kg
	50	4500	165	507	295	90 Kg

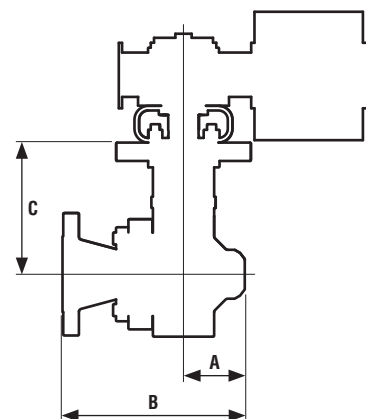

¹For valve bore sizes 1.30 and 2.125 inches, contact factory for dimensions.

²F22 not recommended for prolonged use above 1100°F / 593°C per ASME B16.34.

Temperature vs Pressure — Standard Class Ratings																	
Class	Mat'l.	Temperature (°F)															
		-20 to 100	200	300	400	500	600	650	700	750	800	850	900	950	1000	1050	1100
ASME 1500 Maximum Pressure (psig)	F22 ²	3750	3750	3640	3530	3325	3025	2940	2840	2660	2540	2435	2245	1930	1335	875	550
ASME 2500 Maximum Pressure (psig)	F22 ²	6250	6250	6070	5880	5540	5040	4905	4730	4430	4230	4060	3745	3220	2230	1455	915
ASME 4500 Maximum Pressure (psig)	F22 ²	11250	11250	10925	10585	9965	9070	8825	8515	7970	7610	7305	6740	5795	4010	2625	1645

Class	Mat'l.	Temperature (°C)																		
		-29 to 38	50	100	150	200	250	300	325	350	375	400	425	450	475	500	538	550	575	600
ASME 1500 Maximum Pressure (barg)	F22 ²	259	259	258	251	243	232	214	207	201	194	183	175	169	158	141	92	78	53	34
ASME 2500 Maximum Pressure (barg)	F22 ²	431	431	429	418	405	386	357	344	335	323	305	292	282	264	235	154	130	88	57
ASME 4500 Maximum Pressure (barg)	F22 ²	776	776	773	753	730	695	643	620	603	582	549	525	507	475	423	277	235	158	103