

Saunders

Type A – Bonnet variations

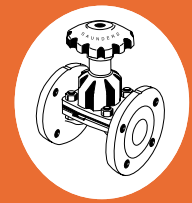

**Industrial
Diaphragm Valves**

IDV/004/01/04.99

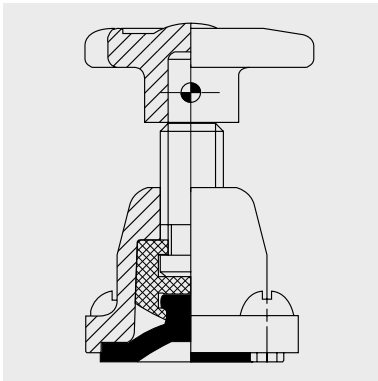

Rising Handwheel
Valve sizes: DN8 to DN10

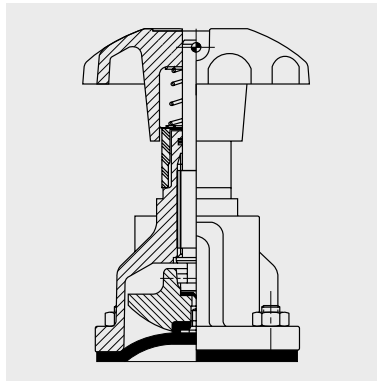

Viton Sealed Bonnet
Valve sizes: DN15 to DN150

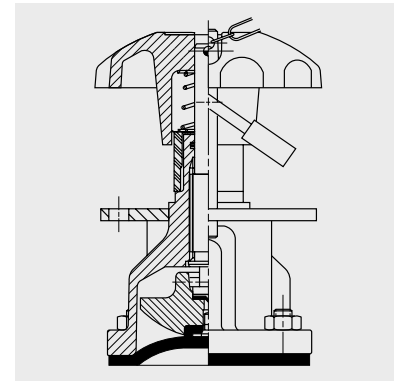

Viton Sealed Padlocking
Valve sizes: DN15 to DN150

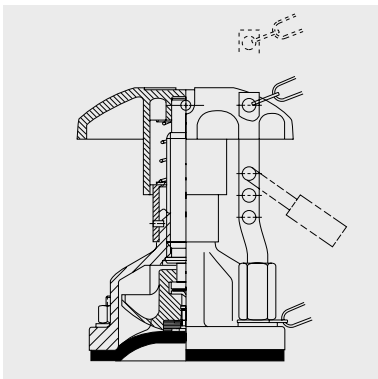

**Rising Handwheel Indicator
(simple padlocking)**
Valve sizes: DN15 to DN150

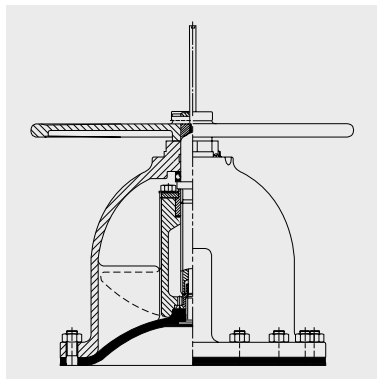

**Non-rising Handwheel
with Indicator**
Valve sizes: DN200 to DN300

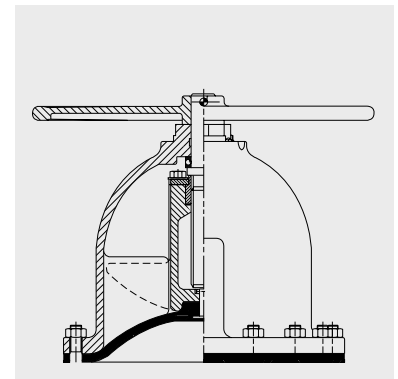

Non-rising Handwheel
Valve sizes: DN200 to DN350

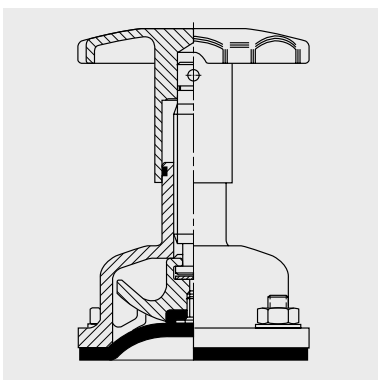

**Stainless Steel
'Silicone sealed'**
Valve sizes: DN8 to DN80

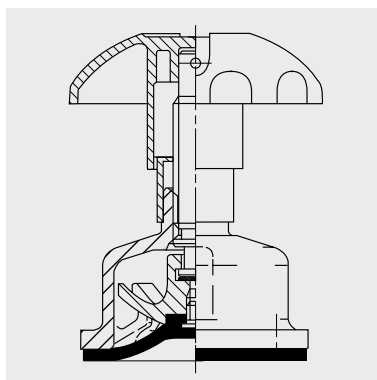

**Stainless Steel
'Non-sealed'**
Valve sizes: DN15 to DN80

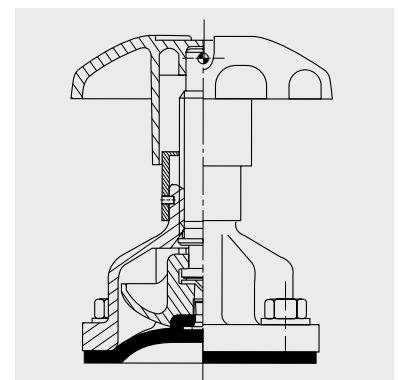

IXEF Polyamide Bonnet
Valve sizes: DN15 to DN50

* Please note that bonnet design will vary throughout the size range available, for each option.

Type A – Bonnet Variations

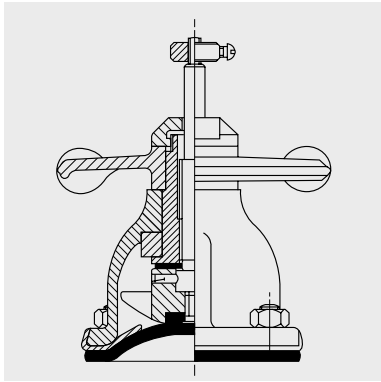

Cast Steel Rising Spindle Indicator (with limit stop)
Valve sizes: DN15 to DN300

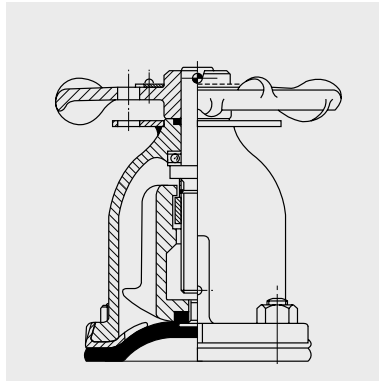

Non-rising Gunmetal LG4 Padlocking
Valve sizes: DN15 to DN200

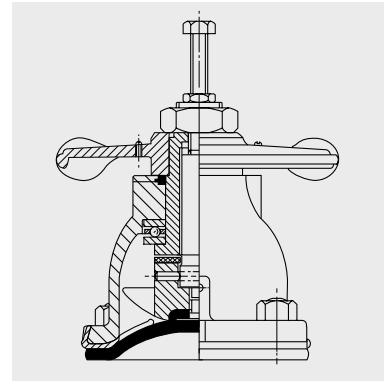

Non-rising Gunmetal LG4 Limit opening
Valve sizes: DN15 to DN150

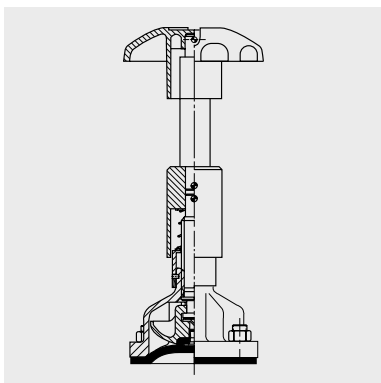

Extended Spindle (rising handwheel design changes to non-rising at DN200)
Valve sizes: DN15 to DN350

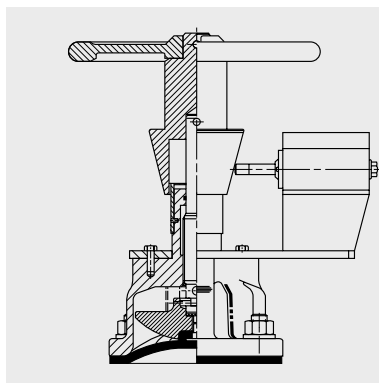

Rising Handwheel with microswitch
Valve sizes: DN25 to DN150

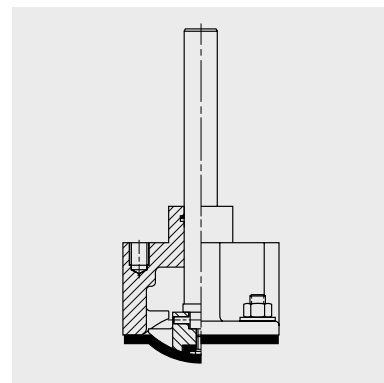

Sliding Spindle (for use with proprietary actuator)
Valve sizes: DN15 to DN350

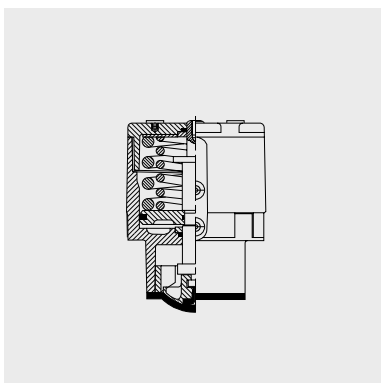

EC actuator (spring close/spring open/double acting)
Valve sizes: DN8 to DN50

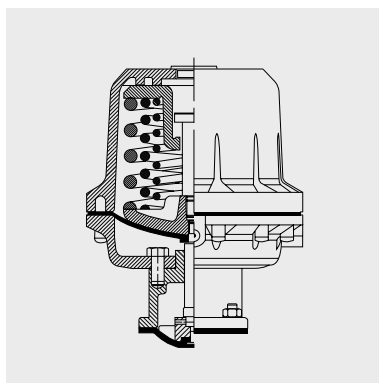

ECX actuator (spring close/spring open/double acting)
Valve sizes: DN65 to DN150

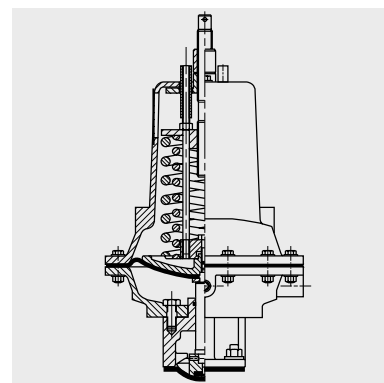

ES failsafe actuators (spring close/spring open/double acting)
Valve sizes: DN8 to DN250

** Please note that bonnet design will vary throughout the size range available, for each option.*