

MCF Ball Valve Overview

The center of MCF modular three-piece valve construction, ISO 5211 type body configuration accommodates a wide choice of seats, seals, accessories and end pieces for almost every type of manual or automated application.

Flow control advantages for both manual and automated valves include:

- Pressure loaded seats with low torque design to provide a consistent bi-directional, bubble-tight seal.



ISO 5211 type bolt pattern and centering lip in the forged 316L stainless or A105 carbon steel center sections ensure alignment of bracket and actuator assembly.

- Fully encapsulated body seals to prevent leaks to atmosphere, while simultaneously allowing welding in-line without time-consuming and costly valve disassembly.
- Live loaded, anti-static stem packing assembly to automatically compensate for wear and thermal expansion and contraction.



Matching ISO 5211 type bolt and centering pattern in the bracket allow quick installation of actuators. Secondary containment units with ISO 5211 configurations fit between valve pad and bracket assembly.

A precision machined, solid 316/316L stainless steel ball and blow-out proof bottom entry stem design combine to direct unrestricted flow, with maximum operating safety, through a 316L stainless or A105 carbon steel body. Fire-safe design is also available.



ISO 5211 type centers retain one bolt removal (swing-out design) for in-line maintenance of internal component parts. Larger valves use a similar "lift out" feature.

ISO 5211 Type Center Section

Precision machined solid 316L stainless steel ball with straight through design. Eliminates the possibility of plated material wearing thin or media turbulence causing restricted flow.

Pressure loaded PTFE seats. Low torque design gives a bubble-tight seal in bi-directional flow. Other materials available for specific media, high pressure and/or high temperature applications. (Optional cavity fillers available for all sizes.)

End pieces in 316L stainless steel or A105 carbon steel. Three piece construction eliminates the need for unions and allows complete versatility of optional end connections in NPT (Threaded), SWE (Socket Weld), BWE (Butt Weld) or Flanged (ANSI Class 150 or 300 raised face) configurations.

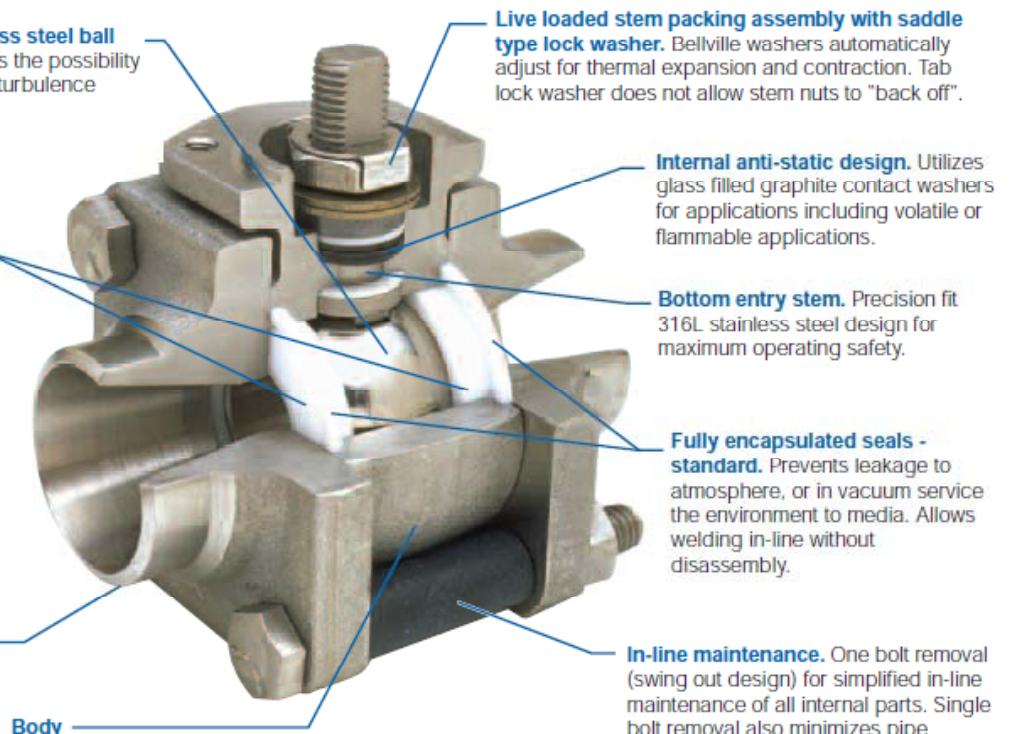

Live loaded stem packing assembly with saddle type lock washer. Bellville washers automatically adjust for thermal expansion and contraction. Tab lock washer does not allow stem nuts to "back off".

Internal anti-static design. Utilizes glass filled graphite contact washers for applications including volatile or flammable applications.

Bottom entry stem. Precision fit 316L stainless steel design for maximum operating safety.

Fully encapsulated seals - standard. Prevents leakage to atmosphere, or in vacuum service the environment to media. Allows welding in-line without disassembly.

In-line maintenance. One bolt removal (swing out design) for simplified in-line maintenance of all internal parts. Single bolt removal also minimizes pipe twisting or distortion during maintenance.

Body
Stainless steel or A105 carbon steel means strong body component integrity capable of withstanding the most severe operating conditions and/or hostile external environments. (Optional purge ports are available.)