

HANCOCK®

Spring loaded, globe style lift check valve may be installed in any position, both in horizontal and vertical piping applications. Class 800 ANSI.

Features

- Disc is spring loaded for positive closure in any position.
- The disc is hardened, ground and lapped, to ensure leak free sealing over the valve's full pressure temperature range.
- Seat is overlaid with Stellite or equal hardfacing.
- The integral seat hardfacing is overlaid directly onto the body base material, eliminating any possibility of leakage behind the seat.
- Flat, precision machined and lapped seating surfaces eliminate damage from high impact seating.
- All internal surfaces are accurately machined to provide maximum performance.
- Socket weld ends standard.
- Standard body and bonnet materials are carbon steel (ASME SA105).
- Code compliance with ASME/ANSI 16.34 and the ASME Boiler and Pressure Vessel Code, Section I.



Applications

5540 series lift check valves are designed for ASME Boiler and Pressure Vessel Code, Section 1 locations and are recommended for applications where leak-tight prevention of flow reversal is required. The 5540 is especially efficient in high temperature/high pressure steam, water and chemical applications.

Sizes/Types

1/2" thru 2": Class 800 LTD class

tyco / Flow Control

Total Flow Control Solutions™

Hancock is either a trademark or registered trademark of Tyco International Services AG or its affiliates in the United States and/or other countries. All other brand names, product names, or trademarks belong to their respective holders.

Features

Body Cap Joint, metal-to-metal surface contact for automatic gasket compression and elimination of flange overstressing.

Forged Body and Cap, in full accordance with ASME Boiler and Pressure Vessel Code, Section 1 design and material requirements.

Hardened Disc, precision guided on cap centerpost. Flat seat design ensures positive alignment of seating surfaces, regardless of valve's installed position, and absorbs sudden closure impact.

Hard Faced Seat, all hardfacing is overlaid to extra depth, to ensure maximum reparability.

Full Code Compliance, complies with ASME/ANSI B16.34 and Section I of the ASME Boiler and Pressure Vessel Code, Section 1.

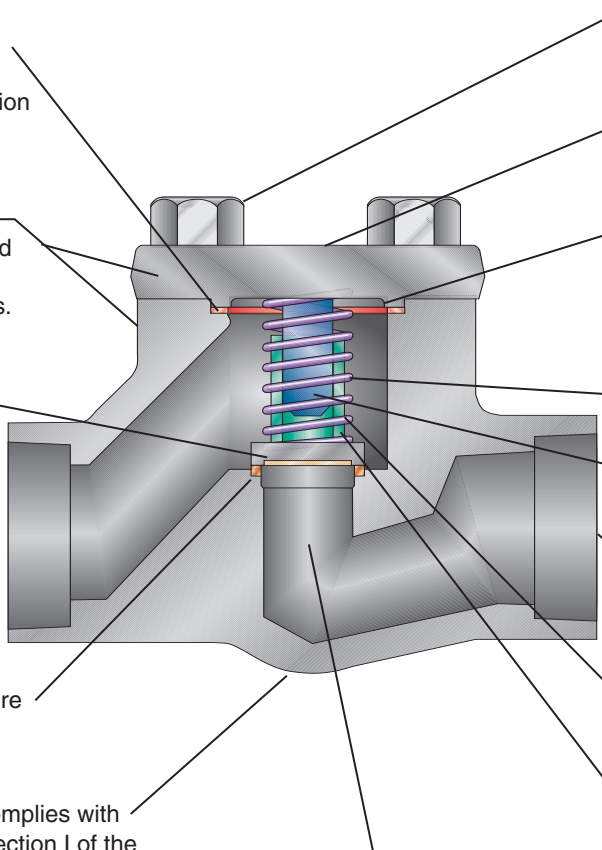

High Strength Bolting, extra heavy hex head cap screws use standard tools for easy maintenance.

Top Entry Design, allows for complete valve maintenance without removal from the line.

Graphite Filled Gasket, spiral wound, stainless steel, graphite filled, with controlled compression for zero leakage at maximum design pressure and temperature.

Inconel® Spring, allows for positive closure at full valve temperature rating.

Center Guided Disc, keeps disc from cocking and/or binding. Prevents galling of stem and disc surfaces.

End Connections, in accordance with ASME/ANSI B16.34 and are available socket weld.

Install in Any Position, spring loaded for positive closure in any installed position.

Built In Relief Port, allows rapid evacuation of line fluid from disc cavity.

Large Ports and Seats, for high flow and low pressure drop. High disc lift allows maximum flow at minimum pressure differential.

Globe Style Lift Check Valves

Check valves, or “non-Return” valves as they are often called, are made in a variety of designs, including globe lift, piston, ball, swing, tilting disc, squib, flapper, etc. All serve the same function, which is to allow flow in one direction, while preventing flow in the other. The most common types of Globe Lift Check valves are T-Pattern and Y-Pattern.

The standard globe type Hancock Lift Check valve consists of a disc (inner valve), encapsulated within a capped body. The disc is spring-loaded, fully guided by the body bore and rests on the valve seat, integral with the body.

The valve is installed with the flow under the disc, such that the inlet line pressure will force the disc to “lift” off the seat and allow the line fluid to flow through the valve. Should the flow suddenly reverse itself, the disc will automatically and

quickly, assisted by the weight of the disc and spring, be forced to the closed position, preventing the line fluid from returning.

Some Lift Check valves have no spring and depend on the weight of the disc to start closure. These are called “horizontal Lift Check valves,” as they will only function properly when installed in a horizontal line. Spring loaded Lift Check valves, like the Hancock 5540, may be installed in any position, both in horizontal and vertical piping applications. The spring also helps reduce noise, and minimize the effect of pulsating flow and “water hammer” line shock.

Y-Pattern Globe style Lift Check valves, with their smoother, less torturous flow passages, usually have a significantly higher flow capacity than T-Pattern designs.

Note

1. Inconel® is a registered trademark of Special Metals Corporation.

Hancock Type 5540

Globe Style Lift Check Valve

Materials of Construction

No.	Part	Material
1	Body	ASME SA105 Carbon Steel
2	Cap	ASME SA105 Carbon Steel
3	Valve	420 Stainless Steel
4	Seat Facing	Stellite or Equivalent
5	Cap Bolt	B7 Alloy Steel (Phosphated)
6	Cap Gasket	304 SS (Graphite) Filled
7	Marker Plate	304 Stainless Steel
8	Metal Tack	304 Stainless Steel
9	Spring	Inconel® X750

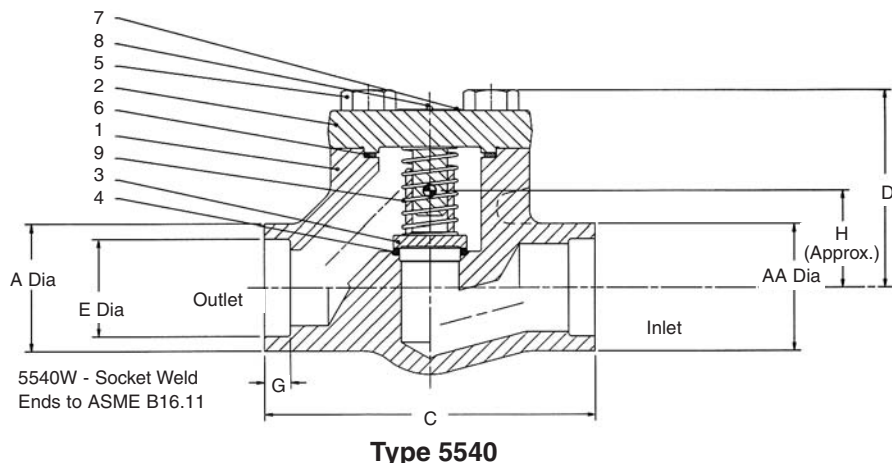

Type 5540 - Dimensions and Weight

Size	A	AA	C	D	E	G	H	Wt.	C _v
1/2"	15/16	15/16	35/16	115/16	0.855	3/8	13/16	3.75	1.8
3/4"	1 1/2	1 1/2	39/16	23/16	1.065	1/2	15/16	4	3.5
1"	1 7/8	1 7/8	4 3/8	2 23/32	1.330	1/2	1 1/8	6.25	6.0
1 1/2"	2 1/2	2 1/2	6 1/2	4 3/16	1.915	1/2	1 5/8	13.5	21.0
2"	3 1/8	3 1/8	7	5	2.406	5/8	2	22.25	23.0

Body, Bonnet and Trim Material Combinations

Variation Suffix No. Valve Types Available	Standard 13% Cr. Trim None 5540S-W
Body	Carbon Steel SA105
Bonnet	Carbon Steel SA105
Seat	Hard Faced with Stellite ¹
Valve Disc	420 SS
Spring	Inconel®
Gasket	304 SS Spiral Wound GRAFOIL® Filled

Notes

1. Or equal.
2. GRAFOIL® is a registered trademark of GrafTech International Holdings Inc.

Figure Numbers Explained

Hancock Forged Steel Valves are available with a variety of standard and special materials, trims and operators. The diagram below is an explanation of Hancock figure numbers.

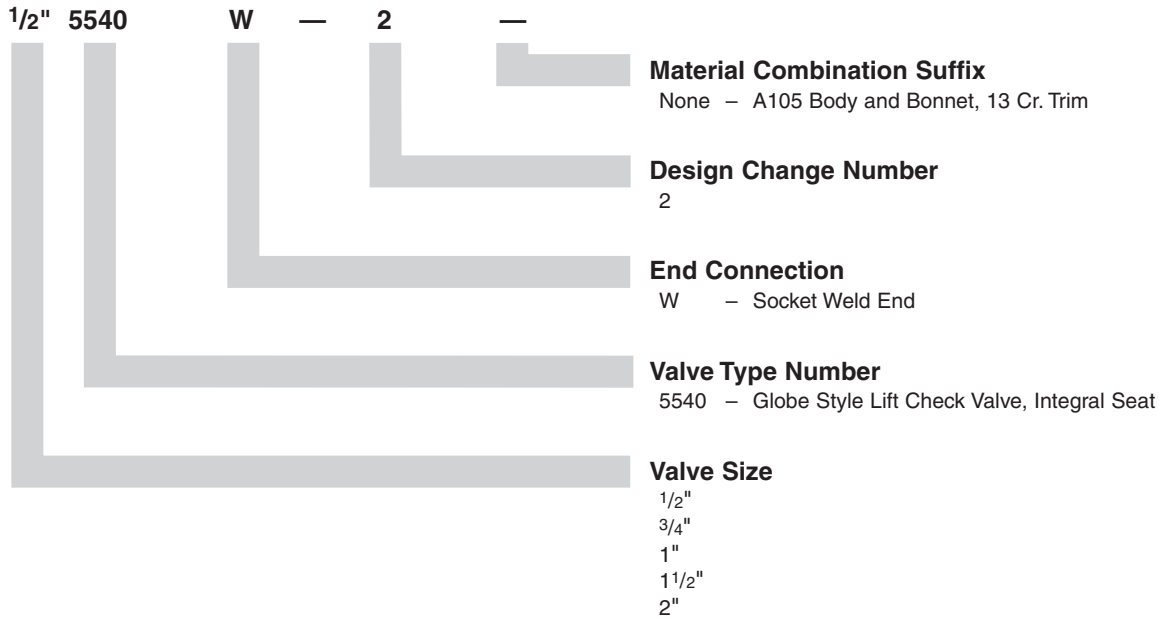

www.tycoflowcontrol.com

Tyco Flow Control (TFC) provides the information herein in good faith but makes no representation as to its comprehensiveness or accuracy. This data sheet is intended only as a guide to TFC products and services. Individuals using this data sheet must exercise their independent judgment in evaluating product selection and determining product appropriateness for their particular purpose and system requirements. TFC MAKES NO REPRESENTATIONS OR WARRANTIES, EITHER EXPRESS OR IMPLIED, INCLUDING WITHOUT LIMITATION ANY WARRANTIES OF MERCHANTABILITY OR FITNESS FOR A PARTICULAR PURPOSE WITH RESPECT TO THE INFORMATION SET FORTH HEREIN OR THE PRODUCT(S) TO WHICH THE INFORMATION REFERS. ACCORDINGLY, TFC WILL NOT BE RESPONSIBLE FOR DAMAGES (OF ANY KIND OR NATURE, INCLUDING INCIDENTAL, INDIRECT, OR CONSEQUENTIAL DAMAGES) RESULTING FROM THE USE OF OR RELIANCE UPON THIS INFORMATION. Patents and Patents Pending in the U.S. and foreign countries. Tyco reserves the right to change product designs and specifications without notice.