

HANCOCK

Direct contact, metal-to-metal seating, makes this globe stop valve ideal for most shutoff applications.

Features

- All valves feature integral Stellite hardfacing on both body and disc seating surfaces.
- Disc guides are also Stellite.
- Fully adjustable yokes.
- Socket weld and butt weld ends are available as standard.
- Bonnets are machined from barstock and yokes are made from die forgings.
- Mechanical bonnet/yoke lock.
- Standard body materials are carbon steel (ASME SA105), alloy steel (ASME SA182 Gr. F22) and stainless steel (ASME SA182 Gr. F316).
- GRAFOIL® packing with braided graphite non-extrusion rings on top and bottom is standard.
- All 1" and larger valves are roddable.
- Full compliance with Section I of the ASME Boiler and Pressure Vessel Code and ASME/ANSI B16.34.



Sizes

1/2" thru 4" : Class 1690 LTD
 : Class 2680 LTD
 : Class 4500 LTD

Options

- Position indicator
- Position switches
- Locking device
- Motor operators
- Handwheel
- Pneumatic operators
- Impact handles and handwheels
- Needle disc

tyco / Flow Control

Total Flow Control Solutions™

GRAFOIL® is a registered trademark of Graftech, Inc.

Hancock is either a trademark or registered trademark of Tyco International Services AG or its affiliates in the United States and/or other countries. All other brand names, product names, or trademarks belong to their respective holders.

Features

Rugged Malleable Iron T-handle - standard on smaller valves. Impactor handwheels on larger models. Handwheels are available for any size valve. Tapered squared stem and socket and extra length handles provide slip free operation, even in tight spaces.

Fully Positionable Forged Yoke - can be locked in any position to accommodate actuator mounting. Eliminates piping interference problems common in conventional designs.

Acme Threads - strength, wear resistance and ease of operation.

Rugged Stainless Steel Stem - heat treated for resistance to galling and corrosion and is suitable for service at over 1000°F.

Standard Hex Gland Nuts - easily adjusted with standard tools.

Forged Steel Gland Flange - high strength, forged alloy steel gland flanges are standard. 1 1/2" and smaller valves have integral gland. Larger valves utilize separate glands.

Mechanical Bonnet Lock - eliminates welding to prevent accidental removal of yoke or bonnet while valve is in service.

Rugged One Piece Stem/Disc - precision ground and heat treated for maximum wear life. Eliminates disc "spinning" vibration, misalignment of seating surfaces, plug cocking and side loading of stem. Non-rotating stem and disc eliminate stem/disc "freezing" and subsequent seat damage.

"Body Guided" Plug - accurately machined disc and body bores provide guiding of the disc over the full valve stroke. Disc guide surfaces are fully hard faced for maximum life.

Renewable Hard Faced Seats - Stellite or equal is standard on all 4000 Series Y-Pattern valves.

Forged Steel Construction - full compliance with ASME Boiler and Pressure Vessel Code, Section I design and material requirements.

Smooth, High Flow Port Design - large port diameters with minimum changes in direction in flow passages allow for high flow rates and minimum pressure drop.

Precision Handle Locknut - standard on all sizes, can't vibrate loose. Holds handle tightly to tapered, squared stem, eliminating play.

Silicon Brass Thread Bushing - made from high strength, anti-galling silicon brass and threaded for easy removal and replacement. Also available in copper-free alloy.

Two-piece Stem Collar - simplifies packing and upper stem replacement, and adaptation of power operators.

Self Lubricated Bearing Pad - metallic composite coated steel pad allows easy upper stem rotation under high thrust loads.

Graphite Packing Rings - built-in corrosion inhibitor for leak tight sealing in high and low temperature applications.

Non-extrusion Rings - prevent packing migration and ensure long service life in high temperature and high pressure applications.

Stainless Steel Packing Stop Ring - heat treated for gall resistant stem guiding.

Integral Back Seat - positive isolation of packing chamber is standard on all 4000 Series Stop valves.

Fully Contained Graphite Gasket - Non-toxic and asbestos free, this material provides excellent sealing at high temperatures.

End Connections Per ANSI B16.34 - valves are available in socket weld and butt weld. Based on size; see page 5.

Flow Control - the caged seat and body guided plug configuration duplicate features found in flow control valves providing excellent controllability over a wide range of valve stroke, a bonus in a valve expressly designed for on/off applications.

Caged Plug Design - reduces high velocity flow during initial opening by keeping the seating surfaces in a specially designed recess until enough lift is attained to assure protection of the sealing surfaces.

Flat Seat Configuration - eliminates misalignment and wear. Makes seat repair easy, as there are no special angles to cut.

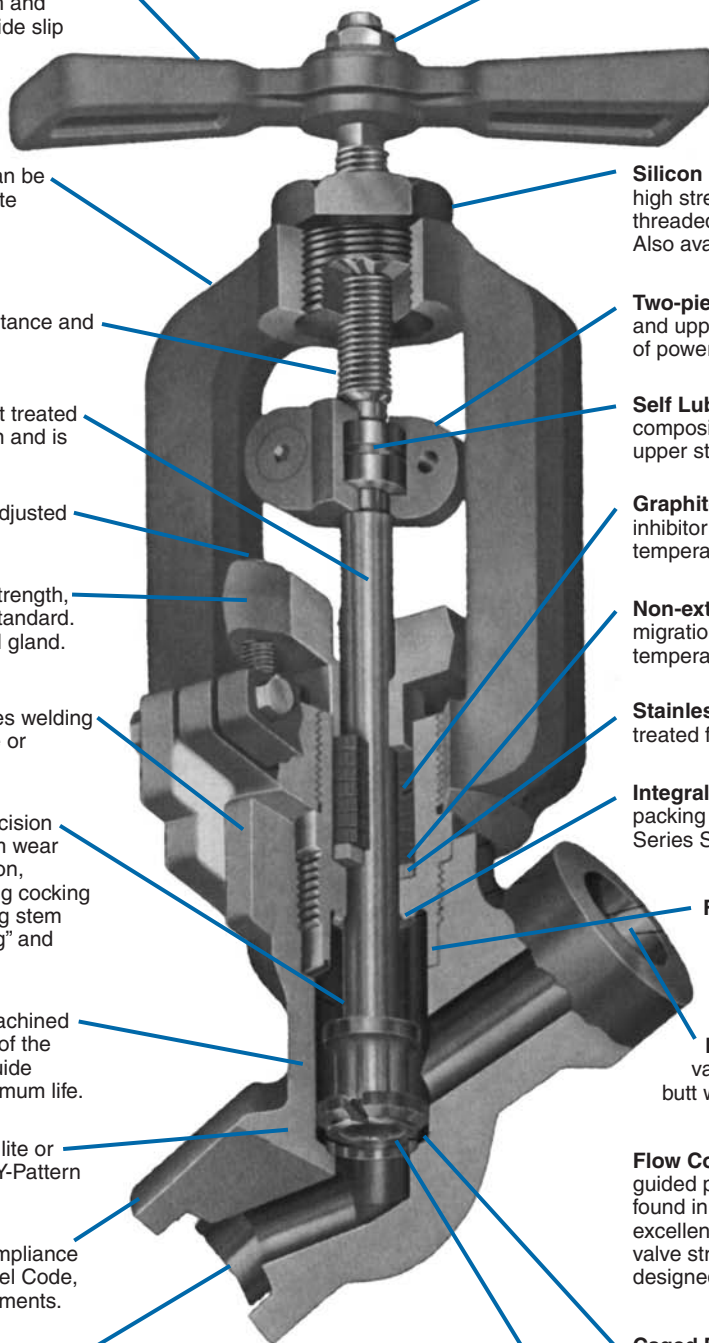

Y-Pattern Globe Stop Valves

Direct contact, metal-to-metal seating, make the globe valve ideal for most shutoff applications. The basic design eliminates the inherent wedge gate valve problem of "wedge sticking" caused when high thermal transients or piping load stresses exert such force that the valve won't open. Positive, direct closure discs allow for accurate control over the initial portion of stem travel, permitting smooth, linear flow, thereby preventing mechanical and/or thermal shock to the valve, down stream piping or expensive machinery.

An outstanding feature of a conventional globe valve is its ability to handle flow around the full seat diameter from the instant it starts to open. The high velocities occurring during the initial opening of a conventional globe valve are distributed evenly and simultaneously

across the entire seating surface. It is this characteristic that helps protect the seating surfaces from erosion and helps to prevent high velocity fluid and cavitation from damaging the valve's downstream body walls or related piping.

The availability of metal-to-metal seating gives globe valves the ability to withstand high temperatures. Hard faced seats enhance the globe valve's ability to hold up in abrasive and high velocity environments. A wide variety of body and trim materials permit its use in severe and corrosive service applications.

The globe valve's top entry design makes it easy to service and maintain. Y-Pattern designs offer substantially increased flow capacities while retaining all the features and benefits of the conventional T-Pattern designs.

Selection

Y-Pattern Globe Stop valves can be used in a wide variety of services and applications. They are especially well suited for applications requiring:

- Tight shutoff, high pressures and temperatures
- Slow initial opening times
- Throttling on initial start-up or shutdown
- Rapid actuation or high speed remote operation
- Valve operation during, or after, high thermal or piping stress transient conditions
- Isolation, draining, venting or filling at high pressures and/or temperatures, while having to maintain tight shutoff at maximum operating conditions
- Pressure or temperature equalizing of systems or large valves

When selecting globe valves, utilization of a top entry design, with a non-welded bonnet closure, will permit easy access to internal components for service and parts replacement, without having to remove the valve from the line. The ability to make quick repairs is especially important at start-up time when valve damage from fabrication debris is most likely to cause expensive down time and project delays.

Hancock Y-Pattern Globe Stop Valves - Series 4000

1/2" thru 4" - Forged Steel, ASME Class 1500/4500

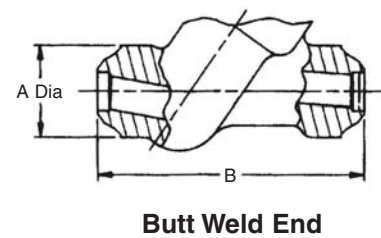
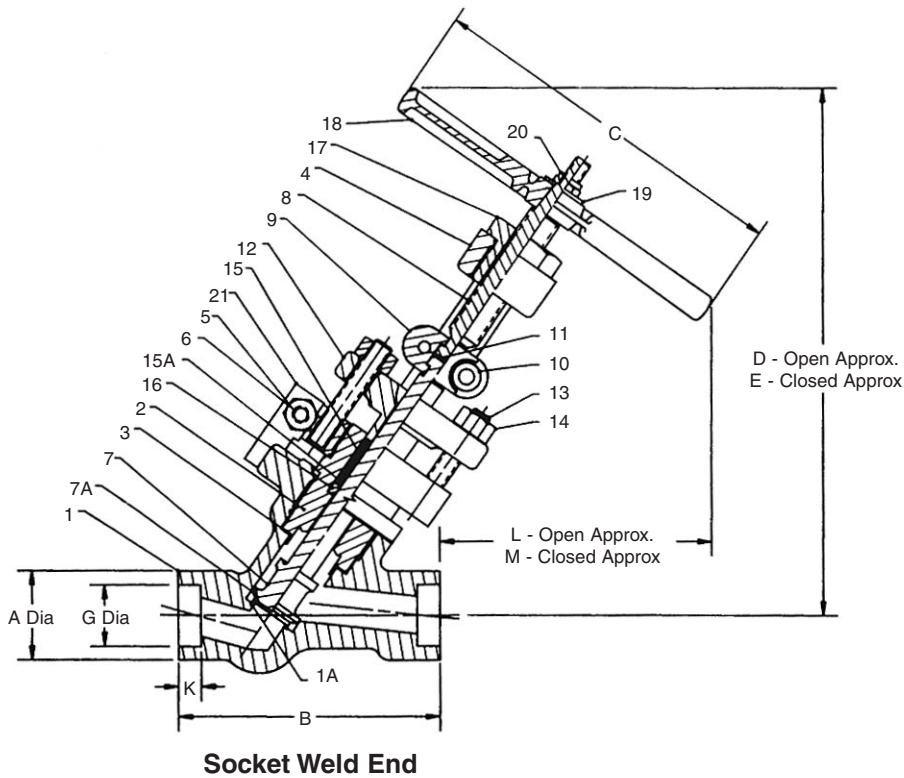

Materials of Construction

No.	Part	Material	Specifications
1	Body	Alloy Steel Carbon Steel	ASME SA182 Gr. F22 ASME SA105
1A	Hardfacing	Stellite 6 or equal	
2	Bonnet	Alloy Steel	ASME SA182 Gr. F22
3	Bonnet Gasket	Compressed Graphite	
4	Yoke	Alloy Steel Alloy Steel - Nickel Plated	ASME SA182 Gr. F22 ASME SA182 Gr. F22
5	Yoke Bolt	Alloy Steel, Carbon Steel Stainless Steel	ASTM A193 Gr. B7 ASTM A193 Gr. B6
6	Yoke Nut	Alloy Steel, Carbon Steel Stainless Steel	ASTM A194 Gr. 2H ASTM A194 Gr. 8
7	Lower Stem/Disc	Alloy Steel, Carbon Steel Stainless Steel	ASTM A276 Type 410 Cond. T 17-4 pH SS (<750°F) Inconel® (>750°F)
7A	Hard Facing	Stellite 6 or equal	
8	Upper Stem	Stainless Steel	ASTM A582 Type 416 - Heat Treated
9	Stem Collar	Nickel Steel	
10	Lock Screw	Cadmium Plated	ASTM A307
11	Bearing Pad	Steel - Self Lubricated	
12	Packing Gland (1/2 - 1")	Alloy Steel	ASME SA182 Gr. F22
12A	Packing Gland (2" and Lgr)	Stainless Steel	ASME SA182 Gr. F316
12B	Pkg. Gland Flange		
13	Pkg. Gland Stud	Alloy Steel, Carbon Steel Stainless Steel	ASTM A193 Gr. B7 ASTM A193 Gr. B6
14	Pkg. Gland Stud Nut	Alloy Steel, Carbon Steel Stainless Steel	ASTM A194 Gr. 2H ASTM A194 Gr. 8
15	Packing	Compressed Graphite	
15A	Non-Extrusion Ring	Braided Graphite Filament	
16	Packing Stop Ring	Stainless Steel	ASTM A582 Type 416 ASTM A276 Type 316
17	Thread Bushing	Silicon Brass	ASTM B371 Alloy C69400
18	Handle	Malleable Iron	ASTM A47 Gr. 32510
18A	Impactor Handle	Malleable Iron	ASTM A47 Gr. 32510
18B	Impactor Handwheel	Malleable Iron	ASTM A47 Gr. 32510
18C	Hi-Tork Bushing	Malleable Iron	ASTM A47 Gr. 32510
19	Handle Washer	Carbon Steel	
20	Handle Nut	Carbon Steel	
21	Lock Plate	Carbon Steel	

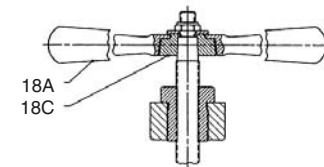
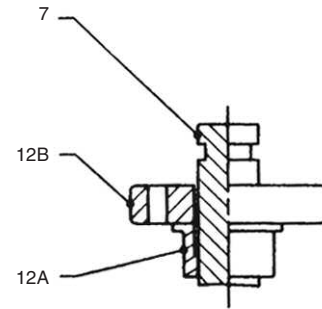

Impactor Handle

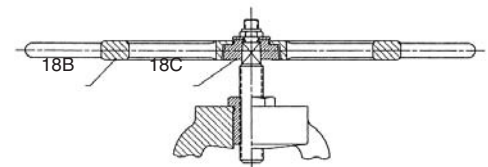

Impactor Handwheel

Note

1. Inconel® is a registered trademark of Special Metals Corporation.

1690 Class Dimensions, Weights and C_v Values

Size	A	B	C	D	E	G	K	L	M	Wt	C _v	End Connections
1/2"	1.81	4.75	6.00	10.06	9.43	0.85	0.37	5.00	4.56	8	6.5	SW
3/4"	1.81	4.75	6.00	10.06	9.43	1.06	0.50	5.00	4.56	8	7.5	SW
1"	1.93	5.75	8.12	12.25	11.37	1.33	0.37	6.50	5.87	13	14	SW
1 1/2"	2.68	7.50	12.50	16.75	15.50	1.91	0.37	10.25	9.18	29	41	SW
2"	3.31	9.50	19.50	22.25	20.50	2.40	0.62	15.50	13.75	59	75	SW
2 1/2"	4.00	10.00	19.50	22.50	20.50	2.90	0.62	15.75	13.62	90	131	SW / BW
3"	5.00	12.50	21.00	28.62	26.31	N/A	N/A	17.81	15.93	180	150	BW
4"	5.00	12.50	21.00	28.62	26.31	N/A	N/A	17.81	15.93	180	150	BW

SW = Socket Weld, BW = Butt Weld

2680 Class Dimensions, Weights and C_v Values

Size	A	B	C	D	E	G	K	L	M	Wt	C _v	End Connections
1/2"	1.81	4.75	6.00	10.06	9.43	0.85	0.37	5.00	4.56	8	6.5	SW
3/4"	1.81	4.75	6.00	10.06	9.43	1.06	0.50	5.00	4.56	8	7.5	SW
1"	2.25	5.87	8.12	12.25	11.37	1.33	0.37	6.37	5.75	17.5	14	SW
1 1/2"	3.12	8.12	12.50	16.75	15.50	1.91	0.37	9.75	8.68	35	32	SW
2"	3.87	10.00	19.50	22.25	20.50	2.40	0.62	15.00	13.25	73	75	SW
2 1/2"	5.00	12.50	19.50	28.62	20.50	2.90	0.62	17.81	15.93	185	100	SW / BW
3"	5.00	12.50	21.00	28.62	26.31	N/A	N/A	17.81	15.93	182	100	BW
4"	5.00	12.50	21.00	28.62	26.31	N/A	N/A	17.81	15.93	182	100	BW

SW = Socket Weld, BW = Butt Weld

4500 Class Dimensions, Weights and C_v Values

Size	A	B	C	D	E	G	K	L	M	Wt	C _v	End Connections
1/2"	2.68	7.50	8.12	15.50	14.62	0.85	0.37	8.75	8.00	25	4.5	SW
3/4"	2.68	7.50	8.12	15.50	14.62	1.06	0.50	8.75	8.00	25	4.5	SW
1"	3.12	8.12	8.12	15.50	14.62	1.33	0.37	8.18	7.43	30	4.5	SW
1 1/2"	5.00	12.50	19.50	20.75	19.75	1.91	0.37	11.62	10.67	60	13	SW
2"	5.56	12.37	19.50	24.06	22.56	2.40	0.62	12.25	11.25	78	40	SW
2 1/2"	6.50	14.25	21.00	30.62	28.81	2.90	0.62	18.56	17.06	290	65	SW / BW
3"	6.50	14.25	21.00	30.62	28.81	N/A	N/A	18.56	17.06	285	65	BW
4"	6.50	14.25	21.00	30.62	28.81	N/A	N/A	18.56	17.06	280	65	BW

SW = Socket Weld, BW = Butt Weld

Automated Valves

Hancock Forged Steel Valves are available with most standard types of electric or pneumatic motor, as well as pneumatic diaphragm and cylinder operators. Hydraulic and electrohydraulic actuators are also available.

All Hancock valves shipped directly from the factory, undergo complete hydrostatic shell, seat, backseat and functional testing WITH OPERATOR IN PLACE. All testing is completed using the installed operator to actuate the valve.

How To Select Actuators

Selecting the proper actuator type and size is most important to proper valve performance. Actuation speed, availability of power, sufficient voltage or air supply, desired fail safe position and response time, accessibility for operation and maintenance, piping

system configuration, desired location, position of manual override, if required, as well as availability of maintenance service all play an important part in proper actuator selection.

How To Specify Automated Valves

Since all valves are not designed alike, and will, because of variations in seat diameters, packing friction, stuffing box loads, stem diameters, surface finishes, available actuation power supply, etc., require different actuator sizes or, in some cases, even types, it is very critical that the valve manufacturer be given sufficient information to produce the desired results in terms of valve and application performance. The information necessary to ensure optimum performance is listed in the "How to Order" section on page 7.

Simplified Motor Operator Adaptation

The 4000 Series Y-Pattern valves feature a unique motor operator adaptation/conversion system that allows for three quick, accurate, factory installation and easy change out of operators or valves in the field. Manually operated valves can be easily converted to motor operation by disconnecting the stem collar, unscrewing the thread bushing/upper stem assembly from the yoke, and removing the yoke from the bonnet. A specially designed, flanged yoke, available from the factory or local

authorized Hancock distributor, replaces the original yoke. All other parts (i.e., thread bushing/stem assembly, stem collar, bolting, etc.) are reassembled back into the replacement yoke. A standard splined stem coupling replaces the original T-Handle and is fastened in place with the original handle lock nut. No other parts are required. Expensive drive sleeve threading and/or special adapter housings are eliminated.

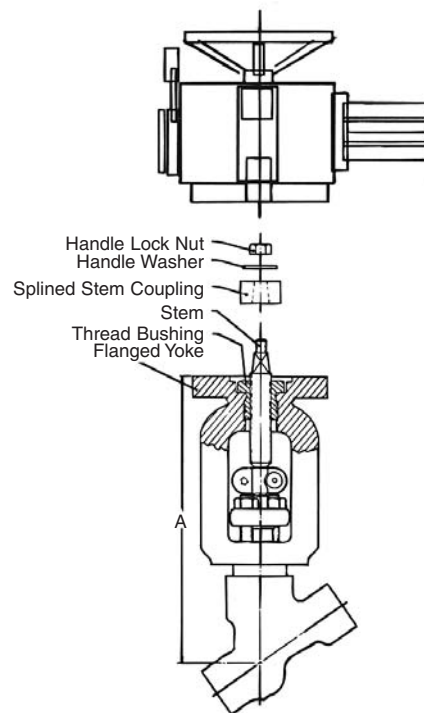

Ordering Information

Figure Numbers Explained

Hancock Forged Steel Valves are available with a variety of standard and special materials, trims and operators. The diagram below is an explanation of Hancock figure numbers.

3" 4 2 9 2 W XXX



Operator Type

None = Manual
Other = Specify

End Connection

W = Socket Weld End
B = Butt Weld End

Material

1 = Carbon Steel (ASME SA105)
2 = Alloy Steel (ASME SA182 Gr. F22)

Valve Type

0 = Globe Stop

Pressure Rating

0 = ASME/ANSI 1690 Limited Class
1 = ASME/ANSI 2680 Limited Class
2 = ASME/ANSI 4500 Limited Class

Valve Type

4 = High Performance Y-Pattern Valve

Size of Connection

1/2"	3/4"	1"	1 1/2"
2"	2 1/2"	3"	4"

How to Order

When ordering Hancock High Pressure 4000 Series valves, please specify quantity, figure number and applicable data below:

A. Quantity Required

B. Nominal Valve Size

1/2"	3/4"	1"	1 1/2"
2"	2 1/2"	3"	4"

C. ASME/ANSI Rating

1690 Ltd	2680 Ltd	4500 Ltd
----------	----------	----------

D. Type of Valve

Hancock Y-Pattern Globe Stop Valve

E. Valve Style

Threaded Bonnet, OS&Y, Integral Backseat
Seal Welded Bonnet, OS&Y Integral Backseat

F. Body Material

ASME SA105 Carbon Steel
ASME SA182 Gr. F22 Alloy Steel

G. Trim Material

Hardfaced Seat and Disc, GRAFOIL® Packing

H. Type of End Connection

Socket Weld End, Butt Weld End
Other (specify)

I. Operator Type

Standard (T-Handle)	Handwheel
Motor	Pneumatic
Other	

J. Figure Number

See chart above

K. Operating Conditions

Working Pressure
Working Temperature
Design Pressure
Design Temperature
Flow Media
Flow Capacity (if applicable)
Application

L. Operator Specifications

Electrical requirements
Actuation supply pressure
Actuation time required
Fail position
Normal position
Manual override
Limit switch(es)
Pilot valve
Locking device
Mechanical position indicator
Potentiometer
Positioner
Other

EXAMPLE: 2 ea., 1 1/2" Hancock Figure No. 4002W, ANSI 1690 Class Y-Pattern Globe Stop Valve, manually operated, OS&Y, ASME SA182 Gr. F22 body with 13% chrome trim. Both seat and disc shall be integrally hardfaced with Stellite or equal. End connections shall be socket weld. Valves must meet the requirements of the ASME Boiler and Pressure Vessel Code, Section I and ASME/ANSI B16.34, and be suitable for the following service conditions:

Operating conditions:

Fluid = _____ at _____ psig and _____ °F;

Required flow rate = _____ lbs/hr.

Design conditions: Fluid = _____ psig and °F;

Design flow rate = _____ lbs/hr.

Hancock Y-Pattern Globe Stop Valves - Series 4000

1/2" thru 4" - Forged Steel, ASME Class 1500/4500

www.tycoflowcontrol.com

Tyco Flow Control (TFC) provides the information herein in good faith but makes no representation as to its comprehensiveness or accuracy. This data sheet is intended only as a guide to TFC products and services. Individuals using this data sheet must exercise their independent judgment in evaluating product selection and determining product appropriateness for their particular purpose and system requirements. TFC MAKES NO REPRESENTATIONS OR WARRANTIES, EITHER EXPRESS OR IMPLIED, INCLUDING WITHOUT LIMITATION ANY WARRANTIES OF MERCHANTABILITY OR FITNESS FOR A PARTICULAR PURPOSE WITH RESPECT TO THE INFORMATION SET FORTH HEREIN OR THE PRODUCT(S) TO WHICH THE INFORMATION REFERS. ACCORDINGLY, TFC WILL NOT BE RESPONSIBLE FOR DAMAGES (OF ANY KIND OR NATURE, INCLUDING INCIDENTAL, INDIRECT, OR CONSEQUENTIAL DAMAGES) RESULTING FROM THE USE OF OR RELIANCE UPON THIS INFORMATION. Patents and Patents Pending in the U.S. and foreign countries. Tyco reserves the right to change product designs and specifications without notice.