



DSI[®] Cast Steel

*Carbon and Stainless Steel
Gate, Globe and Check Valves*



CE



ZY-TECH GLOBAL INDUSTRIES



For years, DSI® Cast Steel Valves have been satisfying the needs of Petroleum Refineries, Chemical Processing Plants, Power Generating Plants, and other processing facilities throughout the world.

Our Cast Steel Valves are designed, engineered and manufactured in strict conformance to



API, ASTM, ASME, ANSI and other recognized standards. DSI® Cast Steel Valves are not only characterized by outstanding performance, reliability and quality, they're also known for their standard features normally optional in other brands. All flanged DSI® Cast Steel Valves come standard with 125-250 RA flange finishes.

DSI® utilizes flexible graphite packing, a variety of gasket materials and exacting assembly & testing procedures to ensure compliance with the World's emissions control standards. Visit our website to find out more about Zy-Tech Global Industries and other DSI® quality products.

Contents

Cast Steel Standard Features	3
Testing, Modifications and Accessories	4
Standard Product Range With DSI® Zy-Gear Bevel Gear Chart	4
NACE Conformance And General Design Specifications	5
Specifying DSI® Carbon Steel Figure Numbers	6
Specifying DSI® Stainless Steel Figure Numbers	7
Gate Valves	8-13
Globe Valves	14-17
Swing Check Valves	18-21
Pressure Temperature Ratings	22
Warranty And Returns Policy	23

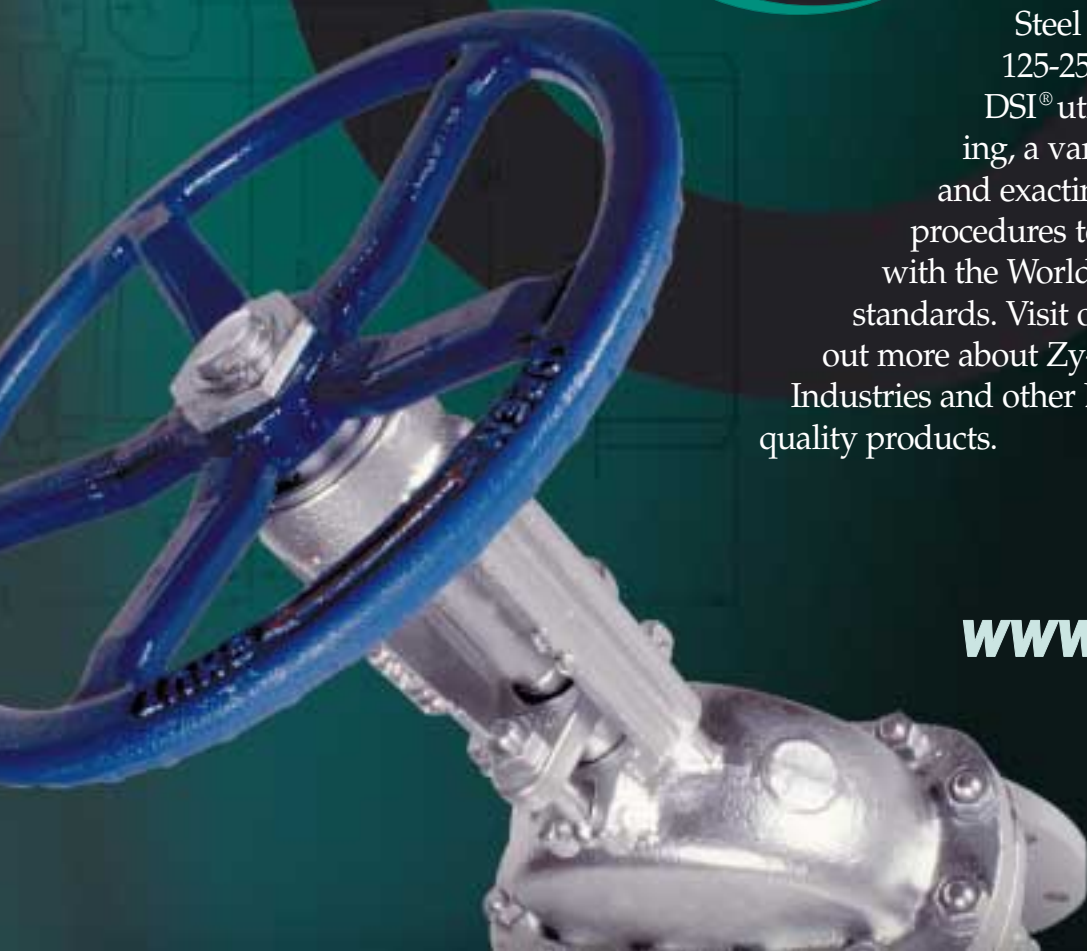

www.zy-tech.com

Get Connected

Standard Features of DSI® Cast Steel Valves

Low Fugitive Emission Service

DSI® standard Cast Steel Gate, Globe and Check Valves are designed and manufactured to ensure leakage of less than 100 ppm (parts per million) of volatile organic compounds.

Extensive base line laboratory testing (static and cycle testing) has been performed establishing critical design parameters necessary to achieve low emission sealing in the DSI® stem packing

seal area for Gate and Globe Valves and in the bonnet gasket sealing area (cover gasket for Check Valves).

In-house testing procedure has been developed and is periodically performed to ensure that standard product design and manufacturing criteria consistently result in the DSI® Gate, Globe and Check Valve meeting a maximum of 100 ppm VOC leakage prior to shipment.

Critical Design and Manufacturing Controls Applied To Produce Low Emission Service Valves In DSI® Standard Products.

- Stem Straightness and Roundness
- Stem Surface Finish To Max. 32 Ra
- Stuffing Box Surface Finish To Max. 125 Ra
- Stuffing Box and Gland Cylindricity
- Self Centering Gland Design
- Gland Packing: Die-formed Graphite Rings with Braided Graphite Top and Bottom Rings.
- Bonnet Gaskets:
 - Class 150 Gate: 316 SS Tanged Clad Graphite
 - Class 150 Globe & Check: 316 SS Spiral Wound Grafoil®
 - Class 300 Valves: 316 SS Spiral Wound
 - Class 600 & Higher: Ring Type Joint

Low Emission Design Options

Live Load Packing

In services requiring frequent cycling or with high pressure/temperature variations, live loading extends the service life between maintenance periods by requiring less frequent packing gland adjustments. Belleville springs are employed to provide constant packing gland stress.

Lantern Ring and Double Packing Set

Lantern ring with leak-off fitting connection and double packing stack is optionally available for critical services.

Packing System

DSI® Cast Steel Gate and Globe valves use a combination of die-formed flexible graphite and interbraided graphite in a predetermined arrangement to ensure an effective seal. Graphite packing achieves its maximum ability to isolate the atmosphere when it is contained within a chamber that is precise in finish

and dimension. DSI® Gate and Globe valves are manufactured with stem finishes better than 32 Ra and stuffing box wall finishes for 125 Ra. In addition, stem straightness and taper are closely controlled.

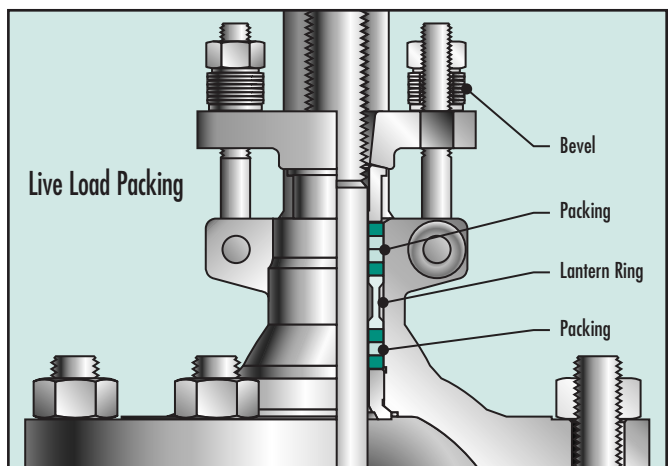
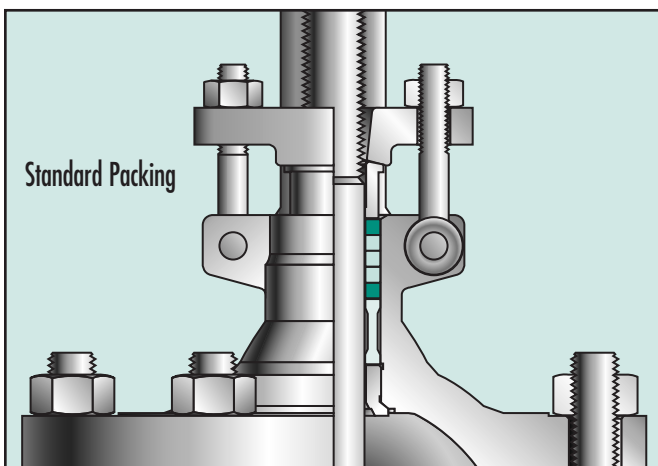

Testing, Modifications and Accessories for DSI® Cast Steel valves

Zy-Tech Global Industries offers In-House NDE Testing, a variety of Product Modifications and Accessories, saving our customers time and resources by eliminating the need for multiple purchase orders, time and transportation costs.

A single warranty then applies to each modified product, with each product inspected for quality and conformance to our customer's specifications and industry standards.

Available Modifications for DSI® Cast Steel Valves

- Packing and Gasket Changes
- End Connection Modifications
- Gear Operator Mounting
- Trim Changes
- Actuation
- Cryogenic Gas Columns
- Hand Wheel Extensions
- Teflon® Disc Inserts
- Drilled & Tapped Body/Bonnet Connections
- By-Pass
- Pressure Equalizing
- Acid Shields
- Oxygen & Chlorine Cleaning & Packaging
- Weld End Bore Changes
- Customer Specified Coatings
- Outside Lever and Weight for Check Valves
- Slam Retarders for Check Valves
- Chain Wheel Operator
- Block and Bleed

NDE Testing Available (In-House)

- Dye Penetrant Test
- Magnetic Particle Test
- Radiography
- PMI (Positive Material Identification)
- API Performance Testing

DSI® Cast Steel Valves Standard Product Range with Zy-Gear Bevel Gear Chart

DSI® offers a broad range of standard commodity Cast Steel Valves in flanged and weld end connections. The chart for Zy-Gears is based on torque ratings for each valve at maximum differential pressure.

Valve Type	Pressure Class	Size Range	Bonnet	Disc	Zy-Gear
Gate	150	2"-48"	Bolted OS&Y	Flex	2"-12" - 107B 14"-24" - 207B 30" & 36" - 307B
	300	2"-30"	Bolted OS&Y	Flex	2"-10" - 107B 12"-20" - 207B 24" & 30" - 307B
	600	2"-24"	Bolted OS&Y	Flex	2"-6" - 107B 8"-12" - 207B 14"-24" - 307B
	900	2"-24"	Bolted OS&Y	Flex	2"-6" - 107B 8"-10" - 207B 12"-16" - 307B
	1500	2"-12"	Bolted OS&Y	Flex	2"-4" - 107B 6"-8" - 207B 10"-12" - 307B
Globe	150	2"-14"	Bolted OS&Y	Plug	2"-14" - 207B
	300	2"-12"	Bolted OS&Y	Plug	2"-8"* - 207B
	600	2"-8"	Bolted OS&Y	Plug	2"-8" - 207B
Swing Check	150	2"-24"	Bolted	Swing	n/a
	300	2"-24"	Bolted	Swing	n/a
	600	2"-16"	Bolted	Swing	n/a



Industry inter-changeable pre-drilled mounting pattern per MSS SP101.

Note: DSI® Cast Steel Globe and Check Valves are available in Classes 900 and 1500. Contact your DSI® salesperson for more information.

*10" & 12" standard from factory.



Conformance

NACE MR0175 Compliant

Over recent years the demand for valves resistant to sulfide stress cracking in facilities handling H₂S bearing hydrocarbons has increased dramatically. Varying concentrations of H₂S, pressure, temperature and the medium itself, whether it be fluid, gas or multi-phase, plus other factors all have a bearing on the appropriate metallic material selection.

DSI® offers three basic valves which have been proven reliable and which fully comply with the NACE MR0175 Latest Edition specification. The typical material configurations of the NACE compliant DSI® Carbon and Low Temperature Carbon Steel Gate Valves are shown below.

NACE Compliant Material Specifications for Gate Valves

Valve Parts	LUF-N Carbon Steel	LUF-N-LCC Low Temp Carbon Steel	XUF-N Carbon Steel	Notes
Body, Bonnet	ASTM A216 WCB	ASTM A352 LCC	ASTM A216 WCB	Maximum hardness 22Rc/235HB
Disc + Disc Faces	4" & under ASTM A182 F316 6" & above ASTM A216 WCB/316	ASTM A352 LCC/316	4" & under ASTM A105/ Stellite® 6, 6" & above ASTM A216 WCB/Stellite® 6	Heat affected zone and weld deposit hardnesses are controlled to 22 Rc/235HB maximum
Stem, Backseat	ASTM A182 F316	ASTM A182 F316	ASTM A276 T410, ASTM A182 F6A	All from solid bar or forging, no welding, maximum hardness 22Rc/235HB
Gland	ASTM A182 F6A	ASTM A182 F316	ASTM A182 F6A	Same as above
Seat + Seat Faces	ASTM A105 plus Stellite® 6 weld deposit	ASTM A352 LF2 plus Stellite® 6 weld deposit	ASTM A105/Stellite® 6	Base material and heat affected zone hardnesses are controlled to 22Rc/235HB maximum, Stellite® 6 facing to NACE MR0175 Sec. 4 and Sec. 5
Bonnet Bolts	ASTM A193 B7M	ASTM A320 L7M	ASTM A193 B7M	Materials are suitable for direct exposure to H ₂ S, NACE MR0175 Sec. 6
Bonnet Nuts	ASTM A194 2HM	ASTM A194 7M	ASTM A194 2HM	Same as above

Note: Other trims available in NACE.

Welding

Welding and weld repair operations are conducted in accordance with applicable ASTM material specifications and NACE MR0175 using procedures and personnel qualified to ASME Section IX.

Material Test Reports

Material test reports for DSI® Cast Steel valves are available upon request. Material test reports meet the requirements of EN 10204 3.1b

General Design Specifications

DSI® Cast Steel Valves are manufactured in strict accordance with the following standards:

American Standard	British Standard	Item Description
API 600	BS1414 (Gate Valve) BS1873 (Globe Valve) BS1868 (Check Valve)	Shell wall thickness and general valve design specifications
ANSI B16.34	BS1560	Pressure temperature ratings
ANSI B16.10	BS2080	Face-to-face dimensions, End-to-end dimensions
ANSI B16.5*	BS1560	End flange dimensions, Gasket contact facing
ANSI B16.25	BS1414 (Gate Valve) BS1873 (Globe Valve) BS1868 (Check Valve)	Welding end dimensions

*Valves 26" and larger according to ANSI B16.47 Series A (MSS SP-44) and Series B (API 605).



DSI® Cast Steel Valves meet all essential safety requirements of the Pressures Equipment Directive 97/23/EC and may be freely marketed in the European Economic Area. DSI® products may be used in applications requiring up to category II product.

Specifying DSI® Cast Carbon Steel Valve Figure Numbers

It's easy to specify DSI® Cast Steel Valves. Just follow the example and use the figure number chart below to specify the valve you need.

Carbon Steel Example:

10" Class 600 Gate Valve with RTJ Flanged Ends operated by a Zy-Gear Bevel Gear Operator, API Trim No. 12 with Flex Wedge, Special NACE Design meeting NACE MR0175 Requirements, and utilizing ASTM A352 LCC for Special Body Material, Graphoil® Packing and Gaskets.

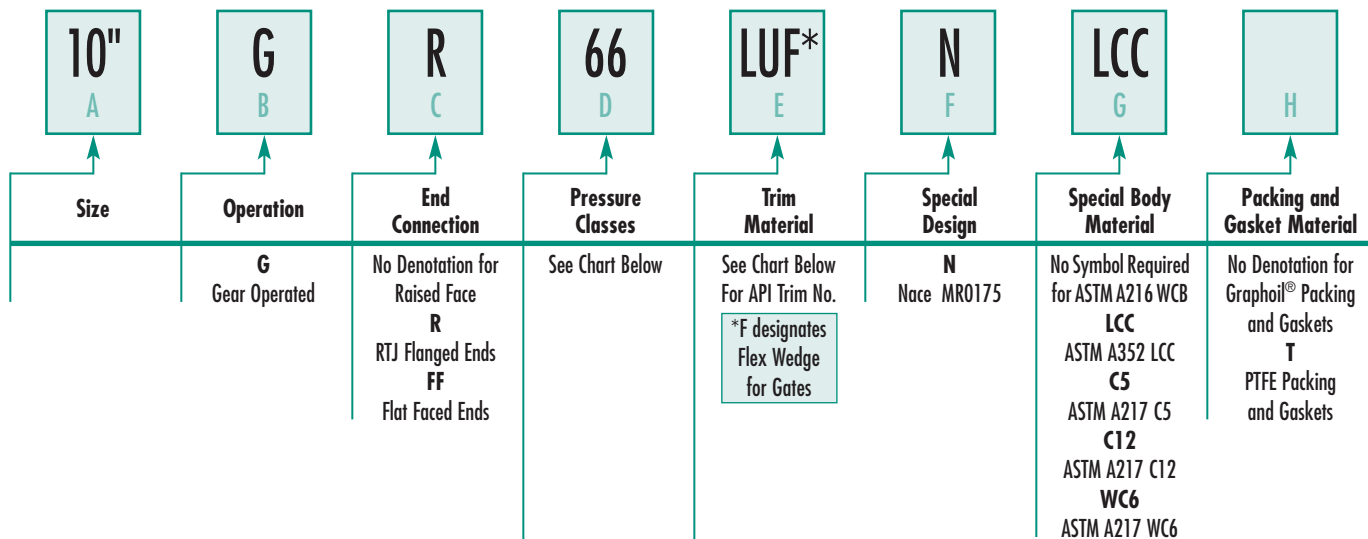

Valve Type	Class	Flanged End	Welding End
Gate	150	37	37 1/2
	300	23	23 1/2
	600	66	66 1/2
	900	73	73 1/2
	1500	77	77 1/2
Globe	150	133	133 1/2
	300	141	141 1/2
	600	161	161 1/2
	900	173	173 1/2
	1500	179	179 1/2
Swing Check	150	137	137 1/2
	300	149	149 1/2
	600	165	165 1/2
	900	177	177 1/2
	1500	189	189 1/2

Symbol	API Trim No.	Seating* Disc/Seat	Stem/Backseat
U	5	HF/HF	13Cr
XU	8	13Cr/HF	13Cr
AU	11	Monel/HF	Monel
LU	12	316/HF	316
L	10	316/316	316
LUU	16**	HF/HF	316
A	9	Monel/Monel	Monel

*Note: HF denotes hardfaced with Stellite® 6.

**Per API 600 10th Edition.

Note: All information is subject to change without notice.





Specifying DSI® API 600 Cast Stainless Steel Valve Figure Numbers

It's easy to specify DSI® API 600 Cast Steel Valves. Just follow the example and use the figure number chart below to specify the valve you need.

Stainless Steel Example:

16" Class 600 Gate Valve with RTJ Flanged Ends, operated by a Zy-Gear Bevel Gear Operator, 316 Stainless Steel and half Stellite® Trim, API 600 Design, utilizing CF8M Stainless Steel Body Material, and Graphoil® Packing and Gaskets.

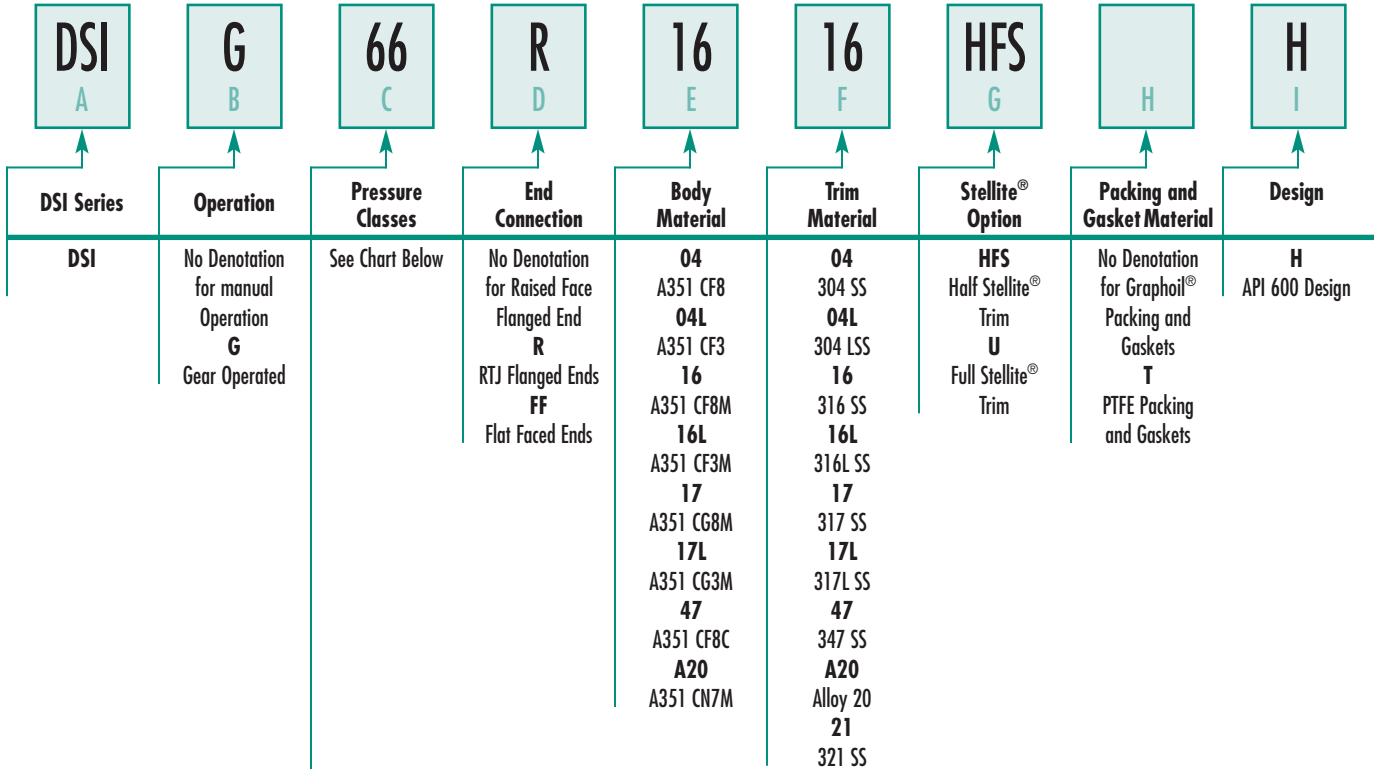

Valve Type	Class	Flanged End	Welding End
Gate	150	37	37 1/2
	300	23	23 1/2
	600	66	66 1/2
	900	73	73 1/2
	1500	77	77 1/2
Globe	150	133	133 1/2
	300	141	141 1/2
	600	161	161 1/2
	900	173	173 1/2
	1500	179	179 1/2
Swing Check	150	137	137 1/2
	300	149	149 1/2
	600	165	165 1/2
	900	177	177 1/2
	1500	189	189 1/2

Note: All information is subject to change without notice.

Gate Valves

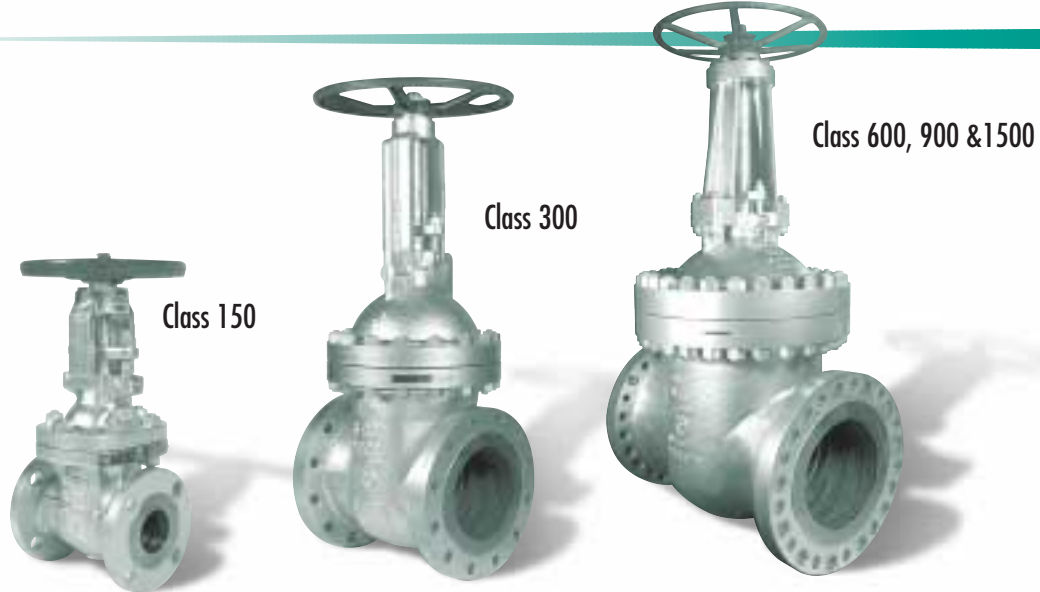

Parts And Materials • Class 150, 300, 600, 900 & 1500

Item	Part Name	WCB	LCC	C5	C12	WC6	CF8M
1	Body	A216 WCB	A352 LCC	A217 C5	A217 C12	A217 WC6	A351 CF8M
2	Bonnet	A216 WCB	A352 LCC	A217 C5	A217 C12	A217 WC6	A351 CF8M
4	Flex Wedge (4" & under)	A105/STL 6	A182 F316	A182 F9/STL 6	A182 F9/STL 6	A182 F6A	A351 CF8M
	Flex Wedge (6" & above)	A216 WCB/STL 6	A352 LCC/F316	A217 C5/STL 6	A217 C12/STL 6	A217 WC6/13Cr	A351 CF8M
5	Seat Rings*	A105/STL 6	A350 LF 2/STL 6	A335-P5/STL 6	AISI 321/STL 6	A335-P5/STL 6	A240 316
6	Stem	A276 410T	A182 F316	A276 410T	A276 410T	A276 410T	A479 316
7	Backseat	A182 F6A	A182 F316	A182 F6A	A182 F6A	A182 F6A	A351 CF8M
8	Studs	A193 B7	A320 L7M	A193 B7	A193 B7	A193 B7	A193 B8
9	Stud Nuts	A194 2H	A194 7M	A194 2H	A194 2H	A194 2H	A194 8
10	Gasket Cl. 150	Graphite GHE					Graphite Sheet
	Gasket Cl. 300	Spiral Wound Metal Graphite					Spiral Wound
	Gasket Cl. 600 & above	Ring Joint					Spiral Wound
11	Handwheel	A47, A356	A47, A356	A47, A356	A47, A356	A47, A356	A197
12	Gland Flange	AISI 1118	AISI 1118	AISI 1118	AISI 1118	AISI 1118	A351 CF8
13	Yoke Sleeve	A439 TYPE D2	A439 TYPE D2	A439 TYPE D2	A439 TYPE D2	A439 TYPE D2	A439 Type D2
14	Handwheel Nut	A47	A47	A47	A47	A47	304 SS
15	Retainer Nut	AISI 1118	AISI 1118	AISI 1118	AISI 1118	AISI 1118	CS 1020+Cr
16	Gland	A182 F6A	A182 F316	A182 F6A	A182 F6A	A182 F6A	-
17	Spacer	A182 F6A	A182 F316	A182 F6A	A182 F6A	A182 F6A	-
18	Eyebolts	A193 B7	A193 B7	A193 B7	A193 B7	A193 B7	A193 B8
19	Eyebolt Pins	AISI 1118	AISI 1118	AISI 1118	AISI 1118	AISI 1118	A479 304
20	Eyebolt Nuts	A194 2H	A194 2H	A194 2H	A194 2H	A194 2H	A194 8
21	Packing	Graphite Stack (Braided and Die-Formed Graphite Rings)					Pillar 6610+6528
23	Grease Fitting	Commercial	Commercial	Commercial	Commercial	Commercial	Commercial
24	Nameplate	AISI 304	AISI 304	AISI 304	AISI 304	AISI 304	-
NPS 14" and Over (12" and Over on Stainless)							
25	Yoke Bearings	Commercial	Commercial	Commercial	Commercial	Commercial	-
26	Studs	A193 B7	A193 B7	A193 B7	A193 B7	A193 B7	A193 B8
27	Stud Nuts	A194 2H	A194 2H	A194 2H	A194 2H	A194 2H	A194 8
31	Yoke	A216 WCB	A352 LCC	A216 WCB	A216 WCB	A216 WCB	A351 CF8
NPS 36"							
28	Studs	A193 B7	A193 B7	A193 B7	A193 B7	A193 B7	-
29	Stud Nuts	A194 2H	A194 2H	A194 2H	A194 2H	A194 2H	-
30	Cover	A216 WCB	A352 LCC	A216 WCB	A216 WCB	A216 WCB	-

*Welded Seat Rings. Contact your DSI® salesperson for more information.





Class 150 Gate Valves

(37-37 1/2)

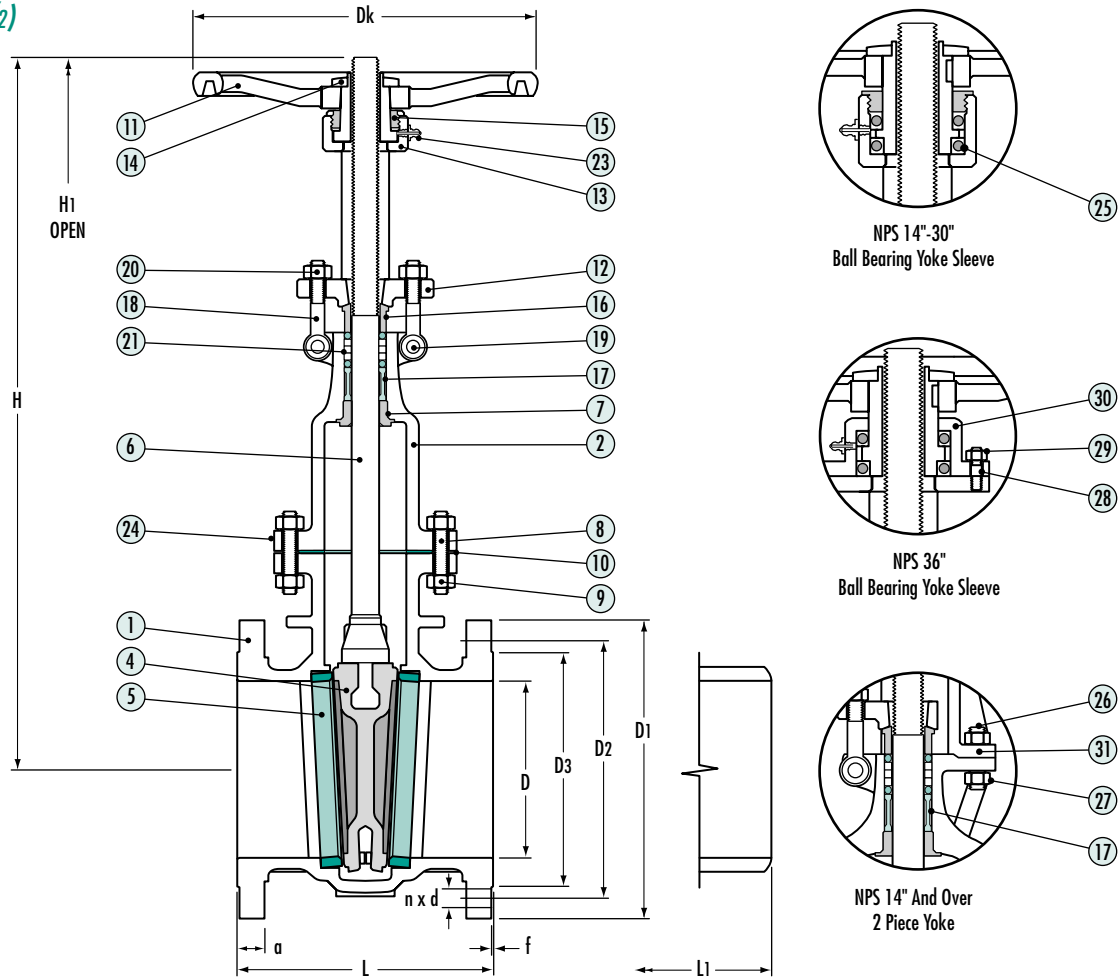

Dimensional Data (in.) and Flow Coefficient (Cv)

End Flange

Size	D	D1	Bolt Hole			D3	a	f	L	L1	H	H1(open)	Dk	Wt. Lbs.	Cv
			D2	n	d										
2	2.00	6.00	4.75	4	0.75	3.62	0.63	0.06	7.00	8.50	12.80	15.63	7.87	45	298.7
2 1/2	2.50	7.00	5.50	4	0.75	4.13	0.71	0.06	7.50	9.50	15.94	19.48	9.84	57	466.7
3	3.00	7.50	6.00	4	0.75	5.00	0.75	0.06	8.00	11.12	16.93	20.55	9.84	66	694.1
4	4.00	9.00	7.50	8	0.75	6.18	0.94	0.06	9.00	12.00	19.09	23.70	9.84	103	1234
6	6.00	11.00	9.50	8	0.87	8.50	1.02	0.06	10.50	15.88	25.91	32.60	11.81	163	2873.9
8	8.00	13.50	11.75	8	0.87	10.63	1.14	0.06	11.50	16.50	30.94	39.69	15.75	273	5109.1
10	10.00	16.00	14.25	12	0.98	12.75	1.22	0.06	13.00	18.00	37.68	48.62	17.72	532	8622.6
12	12.00	19.00	17.00	12	0.98	15.00	1.26	0.06	14.00	19.75	43.70	56.70	19.69	558	12416.5
14	13.25	21.00	18.75	12	1.12	16.25	1.38	0.06	15.00	22.50	47.80	62.09	19.69	860	17651.7
16	15.25	23.50	21.25	16	1.12	18.50	1.46	0.06	16.00	24.00	54.61	71.15	22.05	1235	23055.3
18	17.25	25.00	22.75	16	1.26	21.00	1.57	0.06	17.00	26.00	61.00	79.50	24.80	1455	30603.6
20	19.25	27.50	25.00	20	1.26	23.00	1.69	0.06	18.00	28.00	66.06	86.53	24.80	1742	37782.2
24	23.25	32.00	29.50	20	1.38	27.25	1.89	0.06	20.00	32.00	78.25	102.86	27.95	2557	57349.4
30(A)	29.00	38.75	36.00	28	1.38	33.75	2.95	0.06	24.00	36.00	93.70	124.01	31.50	4674	95044
30(B)	29.00	34.94	33.31	44	0.87	32.00	1.77	0.06	24.00	36.00	93.70	124.01	31.50	4189	95044
36(A)	34.50	46.00	42.75	32	1.61	40.25	3.58	0.06	28.00	40.00	117.68	154.93	35.43	7086	146313.1
36(B)	34.50	41.62	39.75	44	0.98	38.25	2.09	0.06	28.00	40.00	117.68	154.93	35.43	6272	146313.1

Class 300 Gate Valves

(23-23 1/2)

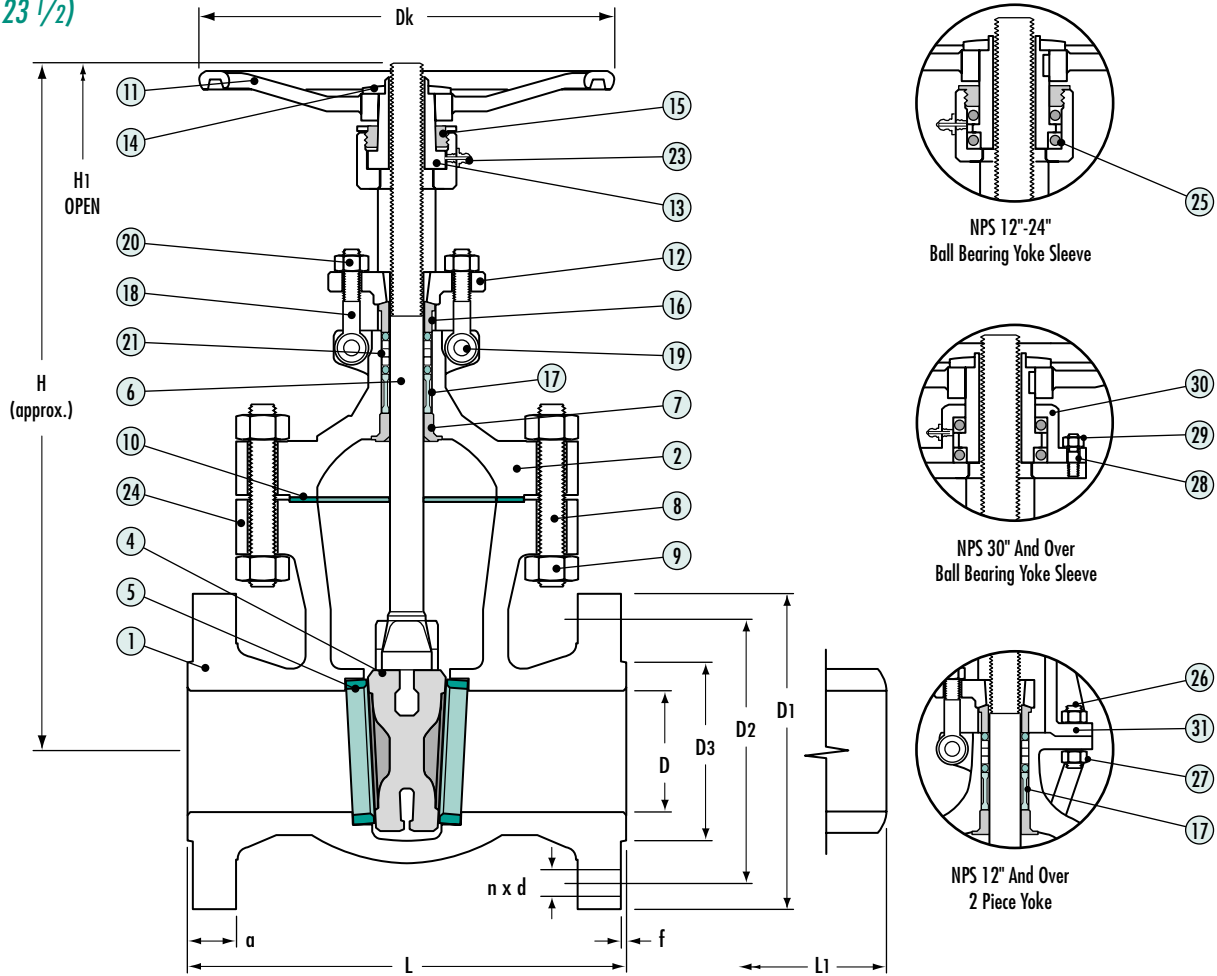

Dimensional Data (in.) and Flow Coefficient (Cv)

End Flange

Size	D	D1	Bolt Hole			D3	a	f	L	L1	H	H1(open)	Dk	Wt. Lbs.	Cv
			D2	n	d										
2	2.00	6.50	5.71	8	0.75	3.62	0.91	0.06	8.50	8.50	14.17	17.00	7.87	60	289.8
2 1/2	2.50	7.50	5.87	8	0.75	4.13	1.02	0.06	9.50	9.50	17.13	20.56	9.84	82	452.8
3	3.00	8.25	6.61	8	0.87	5.00	1.14	0.06	11.12	11.12	18.31	21.93	9.84	98	672.1
4	4.00	10.00	7.87	8	0.87	6.18	1.26	0.06	12.00	12.00	20.47	25.08	9.84	143	1194.8
6	6.00	12.50	10.63	12	0.87	8.50	1.46	0.06	15.88	15.88	27.75	34.44	15.75	296	2776.4
8	8.00	15.00	13.00	12	1.00	10.63	1.65	0.06	16.50	16.50	34.92	44.13	17.72	500	4935.8
10	10.00	17.50	15.25	16	1.12	12.75	1.89	0.06	18.00	18.00	41.26	52.52	19.69	787	7982.9
12	12.00	20.50	17.75	16	1.26	15.00	2.00	0.06	19.75	19.75	44.09	57.09	19.69	1213	11929.4
14	13.25	23.00	20.25	20	1.26	16.25	2.13	0.06	30.00	30.00	49.00	63.29	22.05	1704	15646.6
16	15.25	25.50	22.50	20	1.38	18.50	2.28	0.06	33.00	33.00	55.79	72.33	24.80	2244	21207.8
18	17.00	28.00	24.75	24	1.38	21.00	2.40	0.06	36.00	36.00	61.00	79.50	24.80	2800	26841.1
20	19.00	30.50	27.00	24	1.38	23.00	2.52	0.06	39.00	39.00	67.68	88.15	27.95	3682	34490.3
24	23.00	36.00	32.00	24	1.61	27.25	2.75	0.06	45.00	45.00	79.92	104.53	31.50	5842	51874.4
30(A)	29.00	43.00	39.25	28	1.89	33.75	3.62	0.06	55.00	55.00	102.83	134.25	35.43	9535	85010
30(B)	29.00	39.00	36.25	36	1.50	33.25	3.70	0.06	55.00	55.00	102.83	134.25	35.43	9006	85010
36(A)	34.50	50.00	46.00	32	1.73	40.25	4.13	0.06	68.00	68.00	117.40	154.65	37.25	13029	—
36(B)	34.50	46.10	42.88	32	1.73	39.75	4.09	0.06	68.00	68.00	117.40	154.65	37.25	12346	—



Class 600 Gate Valves

(66-66 1/2)

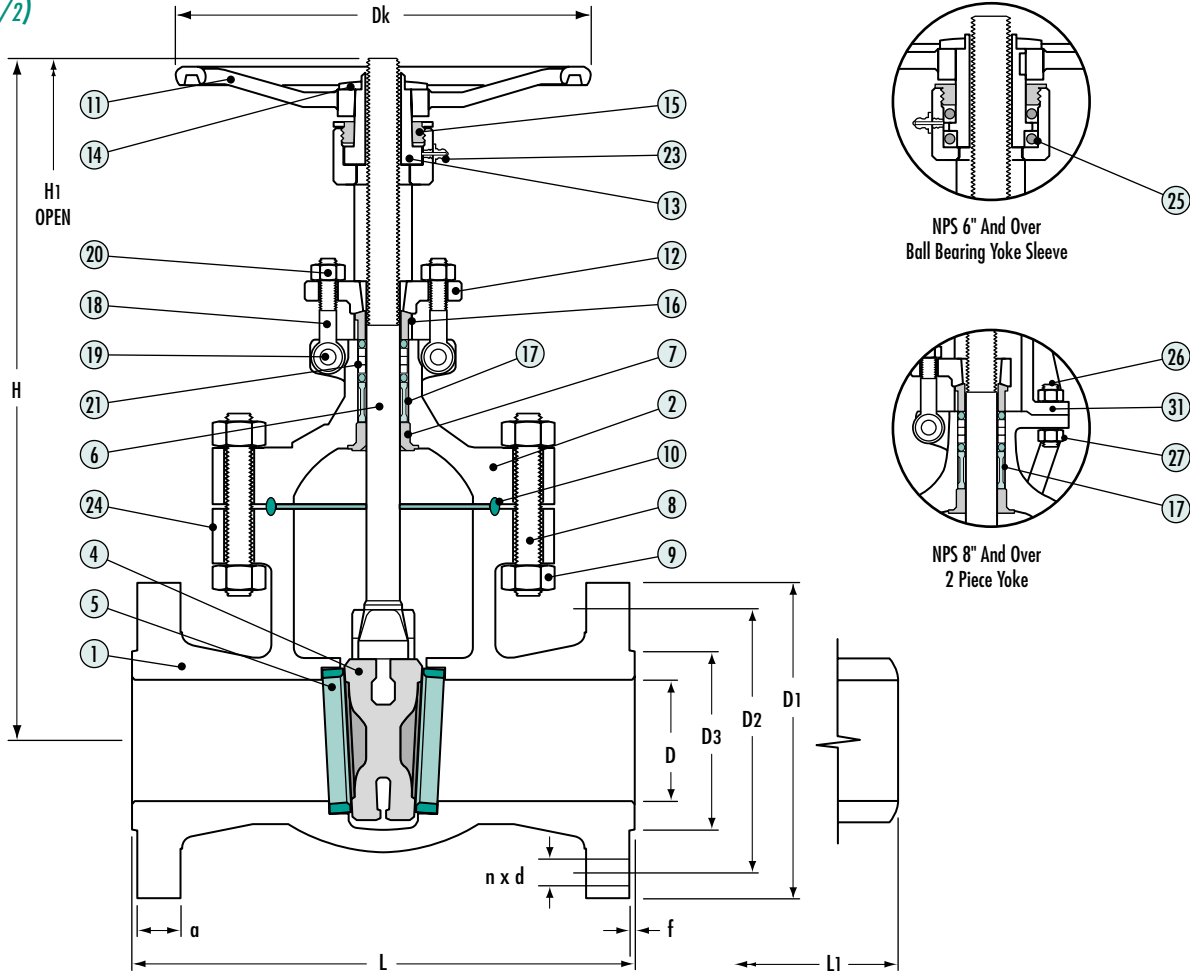

Dimensional Data (in.) and Flow Coefficient (Cv)

End Flange

Size	D	D1	Bolt Hole			D3	a	f	L	L1	H	H1(open)	Dk	Wt. Lbs.	Cv
			D2	n	d										
2	2.00	6.50	5.00	8	0.75	3.62	1.02	0.25	11.50	11.50	14.17	17.00	7.87	90	260.7
2 1/2	2.50	7.50	5.91	8	0.87	4.13	1.14	0.25	13.00	13.00	17.24	20.67	9.84	119	407.4
3	3.00	8.25	6.63	8	0.87	5.00	1.26	0.25	14.00	14.00	17.99	21.61	9.84	133	586.6
4	4.00	10.75	8.50	8	0.98	6.18	1.54	0.25	17.00	17.00	21.61	26.22	11.81	260	1068.6
6	6.00	14.00	11.50	12	1.10	8.50	1.89	0.25	22.00	22.00	31.30	38.58	19.69	719	2404.4
8	7.87	16.50	13.75	12	1.26	10.63	2.20	0.25	26.00	26.00	34.06	42.92	19.69	1025	4385.6
10	9.75	20.00	17.00	16	1.38	12.75	2.52	0.25	31.00	31.00	41.73	52.56	24.80	1709	7244.4
12	11.73	22.00	19.25	20	1.38	15.00	2.64	0.25	33.00	33.00	46.61	59.60	24.80	2271	10753
14	12.87	23.75	20.75	20	1.50	16.25	2.76	0.25	35.00	35.00	55.12	69.88	27.95	2542	15116
16	14.75	27.00	23.75	20	1.61	18.50	3.03	0.25	39.00	39.00	60.83	77.96	27.95	3164	20436.3
18	16.50	29.25	25.75	20	1.73	21.00	3.25	0.25	43.00	43.00	69.29	88.98	31.50	5331	26841.1
20	18.25	32.00	28.50	24	1.73	23.00	3.50	0.25	47.00	47.00	73.62	94.87	31.50	6554	34490.3
24	22.00	37.00	33.00	24	2.00	27.25	4.02	0.25	55.00	55.00	85.83	110.63	35.43	9057	51874.4

Class 900 Gate Valves

(73-73 1/2)

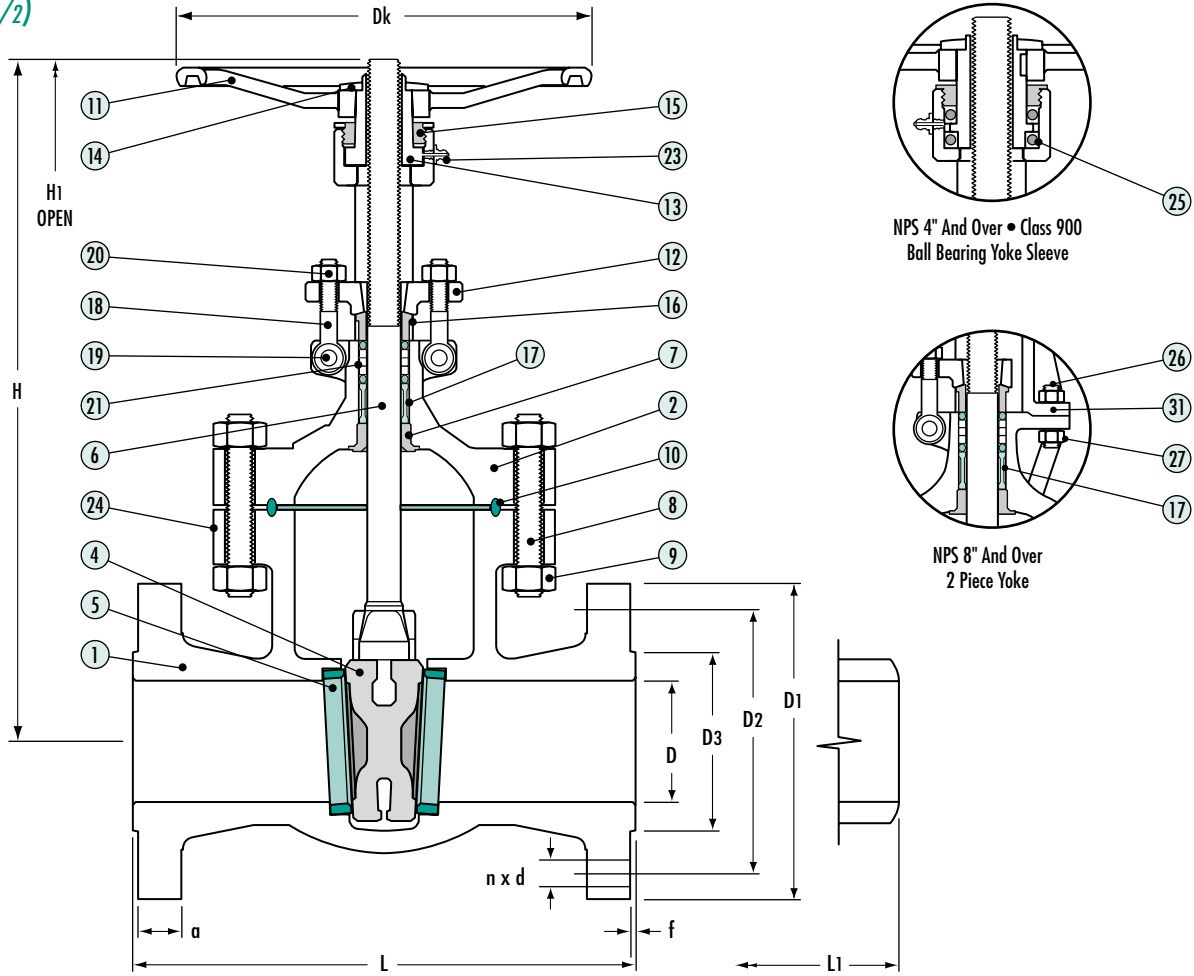

Dimensional Data (in.) and Flow Coefficient (Cv)

End Flange

Size	D	D1	Bolt Hole			D3	a	f	L	L1	H	H1(open)	Dk	Wt. Lbs.	Cv
			D2	n	d										
3	2.87	9.50	7.50	8	0.98	5.00	1.54	0.25	15.00	15.00	20.43	24.43	11.81	236	560.5
4	3.86	11.50	9.25	8	1.26	6.18	1.77	0.25	18.00	18.00	23.90	28.86	15.75	379	1018.9
6	5.75	15.00	12.50	12	1.26	8.50	2.20	0.25	24.00	24.00	31.89	38.98	19.69	842	2346.5
8	7.50	18.50	15.50	12	1.50	10.63	2.52	0.25	29.00	29.00	38.39	47.45	24.80	1466	4274.6
10	9.37	21.50	18.50	16	1.50	12.75	2.75	0.25	33.00	33.00	43.31	53.56	27.95	1973	6852.5
12	11.14	24.00	21.00	20	1.50	15.00	3.12	0.25	38.00	38.00	49.37	62.37	27.95	2877	10138





Class 1500 Gate Valves

(77-77 1/2)

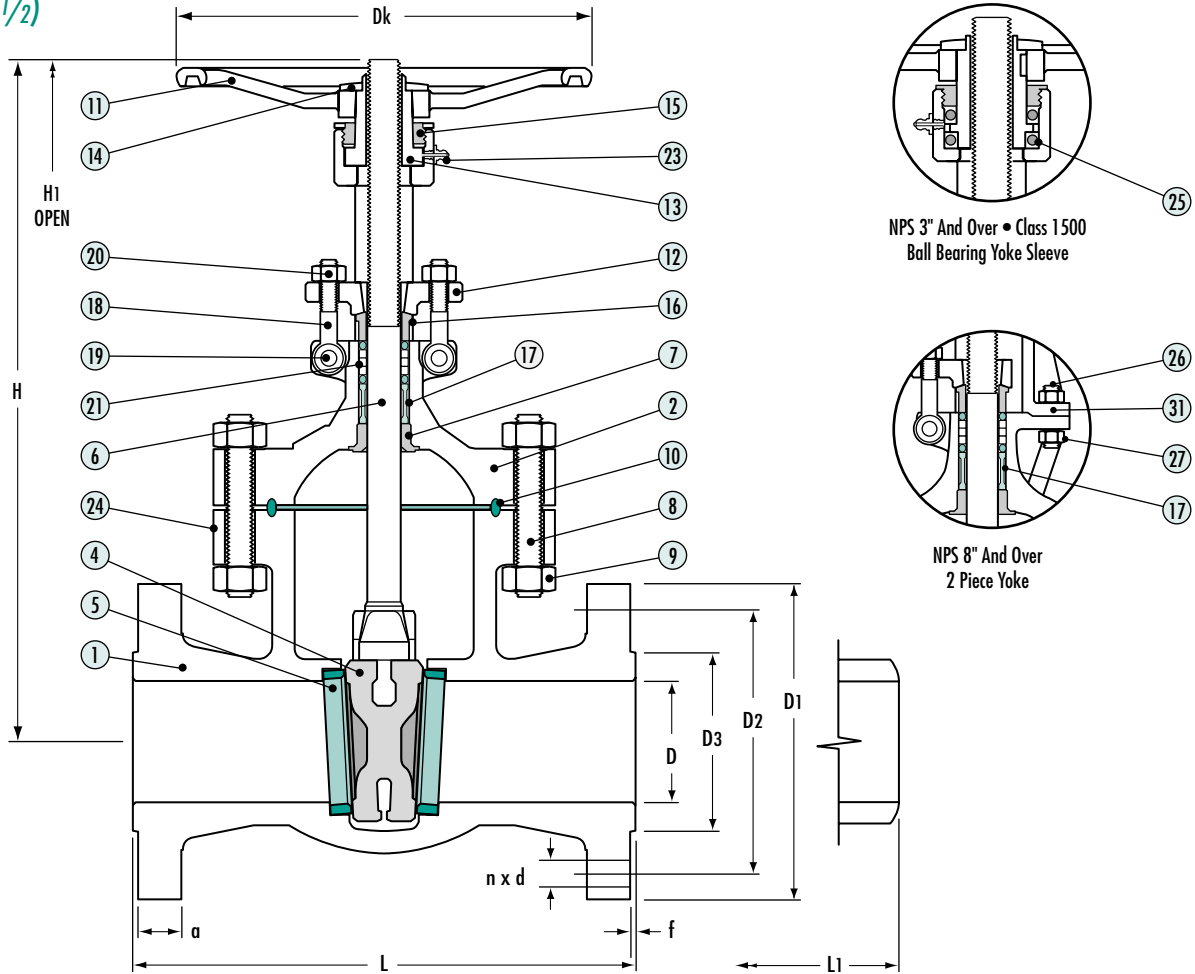

Dimensional Data (in.) and Flow Coefficient (Cv)

End Flange

Size	D	D1	Bolt Hole			D3	a	f	L	L1	H	H1(open)	Dk	Wt. Lbs.	Cv
			D2	n	d										
2	1.97	8.50	6.50	8	0.98	3.62	1.54	0.25	14.50	14.50	18.78	21.61	9.84	188	249.1
3	2.76	10.50	8.00	8	1.26	5.00	1.89	0.25	18.50	18.50	23.43	27.05	15.75	332	537.7
4	3.62	12.25	9.50	8	1.38	6.18	2.13	0.25	21.50	21.50	24.80	29.41	17.72	495	975.5
6	5.39	15.50	12.50	12	1.50	8.50	3.27	0.25	27.75	27.75	32.68	39.88	22.05	1138	2242.2
8	7.00	19.00	15.50	12	1.73	10.63	3.62	0.25	32.75	32.75	38.98	47.64	27.95	2205	4075.6
10	8.78	23.00	19.00	12	2.00	12.75	4.25	0.25	39.00	39.00	46.57	57.36	31.50	3439	6518.1
12	10.39	26.50	22.50	16	2.13	15.00	4.88	0.25	44.50	44.50	51.18	63.78	31.50	4872	9617.8

Globe Valves



Parts And Materials • Class 150, 300, 600, 900 & 1500

Item	Part Name	WCB	LCC	C5	C12	WC6	CF8M
1	Body	A216 WCB	A352 LCC	A217 C5	A217 C12	A217 WC6	A351 CF8M
2	Bonnet	A216 WCB	A352 LCC	A217 C5	A217 C12	A217 WC6	A351 CF8M
4	Disc	A217 CA15	A351 CF8M	A217 C5/STL 6	A217 C12/STL 6	A217 WC6/STL 6	A351 CF8M
	Disc 8"-12"	A216 WCB/13Cr	A352 LCC/F316	A217 C5/STL 6	A217 C12/STL 6	A217 WC6/STL 6	A351 CF8M
5	Seat Ring	A105/STL 6	A352 LF2/F316	A335-P5/STL 6	AISI 321/STL 6	A335-P5/STL 6	A351 CF8M
6	Stem	A276 410T	A182 F316	A276 410T	A276 410T	A276 410T	A479 316
7	Backseat	A182 F6A	A182 F316	A182 F6A	A182 F6A	A182 F6A	A351 CF8M
8	Studs	A193 B7	A320 L7M	A193 B7	A193 B7	A193 B7	A193 B8
9	Stud Nuts	A194 2H	A194 7M	A194 2H	A194 2H	A194 2H	A194 8
10	Gasket Cl. 150	Spiral Wound Graphite					Graphite Sheet
	Gasket Cl. 300	Spiral Wound Graphite					Spiral Wound
	Gasket Cl. 600 & above	RTJ					Spiral Wound
11	Stem Lock Nut	A182 F6A	A182 F316	A182 F6A	A182 F6A	A182 F6A	A479 316
12	Nameplate	AISI 304	AISI 304	AISI 304	AISI 304	AISI 304	—
31	Handwheel	A47, A356	A47, A356	A47, A356	A47, A356	A47, A356	A197
32	Gland Flange	AISI 1118	AISI 1118	AISI 1118	AISI 1118	AISI 1118	A351 CF8
33	Yoke Sleeve	A439 Type D2	A439 Type D2	A439 Type D2	A439 Type D2	A439 Type D2	A439 Type D2
34	Handwheel Nut	A47, A194 2H	A47, A194 2H	A47, A194 2H	A47, A194 2H	A47, A194 2H	A194 8
35	Bonnet	A216 WCB	A216 WCB	A216 WCB	A216 WCB	A216 WCB	—
36	Gland	A182 F6A	A182 F316	A182 F6A	A182 F6A	A182 F6A	A479 316
37	Spacer	A182 F6A	A182 F316	A182 F6A	A182 F6A	A182 F6A	—
38	Eyebolts	A193 B7	A193 B7	A193 B7	A193 B7	A193 B7	A193 B8
39	Eyebolt Pins	AISI 1118	AISI 1118	AISI 1118	AISI 1118	AISI 1118	A479 304
40	Eyebolt Nuts	A194 2H	A194 2H	A194 2H	A194 2H	A194 2H	A194 8
41	Packing	Braided and Die-Formed Graphite Rings					—
43	Bearing	Commercial	Commercial	Commercial	Commercial	Commercial	—
44	Grease Fitting	Commercial	Commercial	Commercial	Commercial	Commercial	—
45	Studs	A193 B7	A193 B7	A193 B7	A193 B7	A193 B7	—
46	Stud Nuts	A194 2H	A194 2H	A194 2H	A194 2H	A194 2H	—
47	Guide	AISI 1118	AISI 1118	AISI 1118	AISI 1118	AISI 1118	—
48	Studs	Commercial	Commercial	Commercial	Commercial	Commercial	—
50	Pins	AISI 1118	AISI 1118	AISI 1118	AISI 1118	AISI 1118	—
51	Hub	A47	A47	A47	A47	A47	—
52	Washer	AISI 1118	AISI 1118	AISI 1118	AISI 1118	AISI 1118	—
30	Gear Cl. 300 10" & 12"	Commercial	Commercial	Commercial	Commercial	Commercial	Commercial

Contact your DSI® salesperson for more information.





Class 150 Globe Valves

(133-133 1/2)

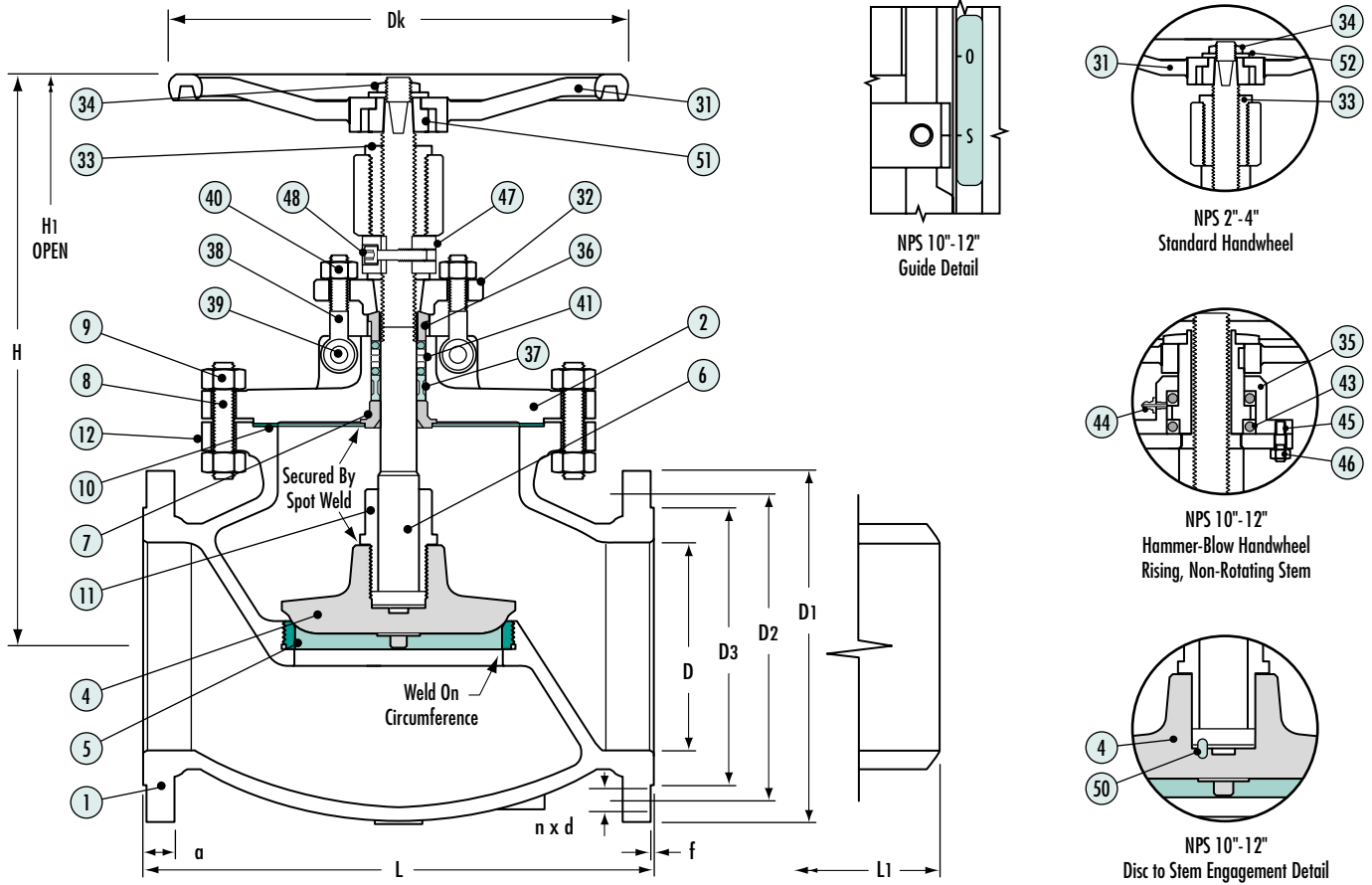

Dimensional Data (in.) and Flow Coefficient (Cv)

End Flange

Size	D	D1	Bolt Hole			D3	a	f	L	L1	H	H1(open)	Dk	Wt. Lbs.	Cv
			D2	n	d										
2	2.00	6.00	4.75	4	0.75	3.62	0.63	0.06	8.00	8.00	13.58	14.96	7.87	55	46.9
2 1/2	2.50	7.00	5.50	4	.75	4.13	0.71	0.06	8.50	8.50	19.30	21.07	9.84	77	72.2
3	3.00	7.50	6.00	4	0.75	5.00	0.75	0.06	9.50	9.50	15.75	17.52	9.84	93	105.5
4	4.00	9.00	7.50	8	0.75	6.18	0.94	0.06	11.50	11.50	18.31	20.28	15.75	143	166
6	6.00	11.00	9.50	8	0.87	8.50	1.00	0.06	16.00	16.00	20.08	22.05	17.72	254	400
8	8.00	13.50	11.75	8	0.87	10.63	1.12	0.06	19.50	19.50	21.97	24.25	17.72	375	810
10	10.00	16.00	14.25	12	0.98	12.75	1.19	0.06	24.50	24.50	29.50	32.10	19.69	617	1310.5
12	12.00	19.00	17.00	12	0.98	15.00	1.25	0.06	27.50	27.50	32.48	35.75	19.69	833	1900.6

Class 300 Globe Valves (141-141 1/2)

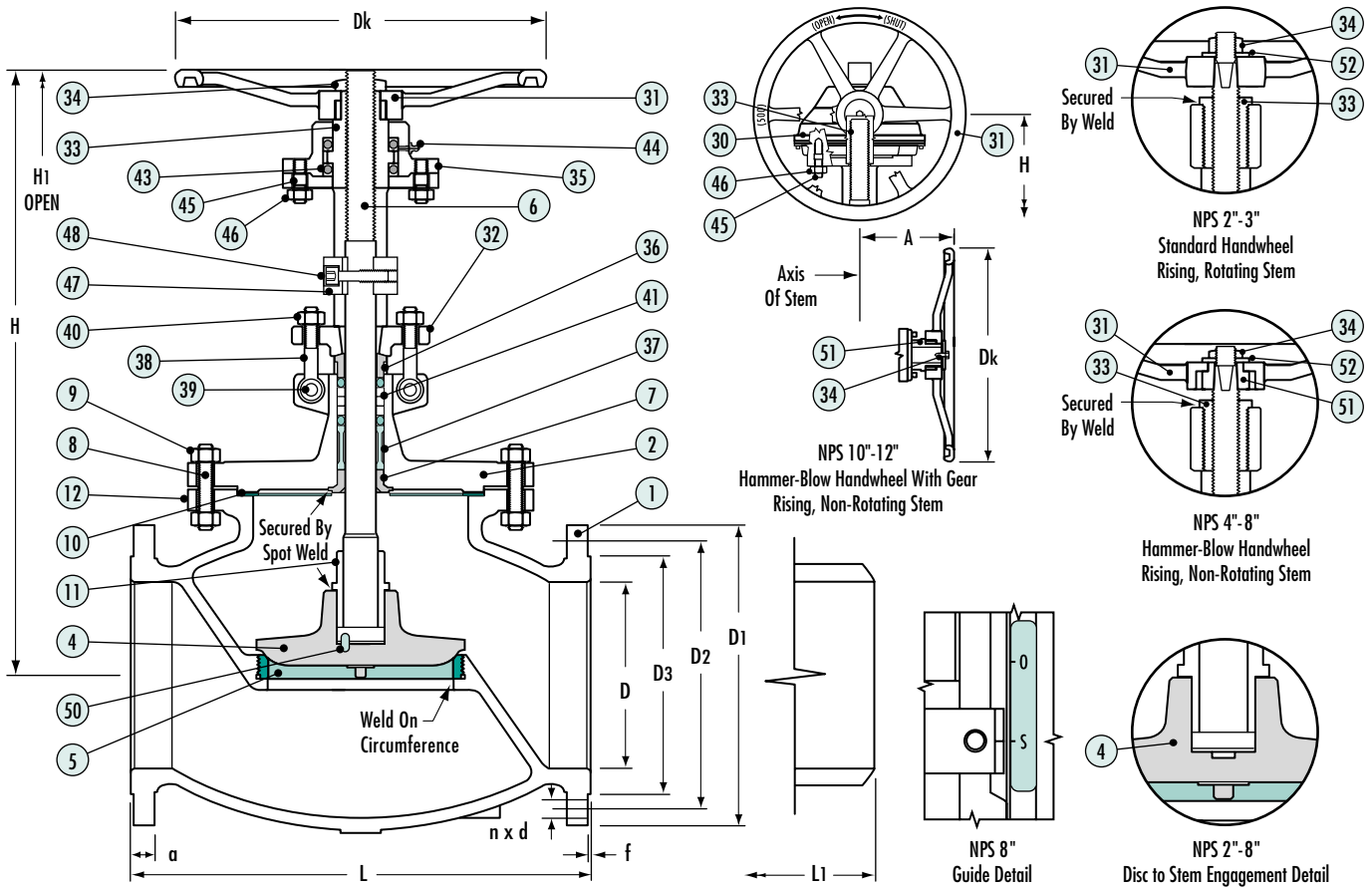

Dimensional Data (in.) and Flow Coefficient (Cv)

End Flange

Size	D	D1	Bolt Hole			D3	a	f	L	L1	H	H1(open)	Dk	A	Wt. Lbs.	Cv
			D2	n	d											
2	2.00	6.50	5.00	8	0.75	3.62	0.91	0.06	10.50	10.50	15.16	16.73	7.87	—	66	46.5
2 1/2	2.50	7.50	5.87	8	0.87	4.13	1.02	0.06	11.50	11.50	17.52	19.10	9.84	—	106	84.5
3	3.00	8.25	6.63	8	0.87	5.00	1.14	0.06	12.50	12.50	17.91	19.88	9.84	—	126	104.7
4	4.00	10.00	7.87	8	0.87	6.18	1.26	0.06	14.00	14.00	20.47	22.44	15.75	—	185	165
6	6.00	12.52	10.63	12	0.87	8.50	1.46	0.06	17.50	17.50	22.83	25.19	17.72	—	357	436.7
8	8.00	15.00	13.00	12	0.98	10.63	1.65	0.06	22.00	22.00	31.10	33.38	19.69	—	617	692.9
10	10.00	17.50	15.25	16	1.12	12.75	1.88	0.06	24.50	24.50	32.64	35.40	19.69	11.10	915	1120.6
12	12.00	20.50	17.75	16	1.26	15.00	2.01	0.06	28.00	28.00	35.35	38.58	27.95	11.10	1276	1882.4





Class 600 Globe Valves (161-161 1/2)

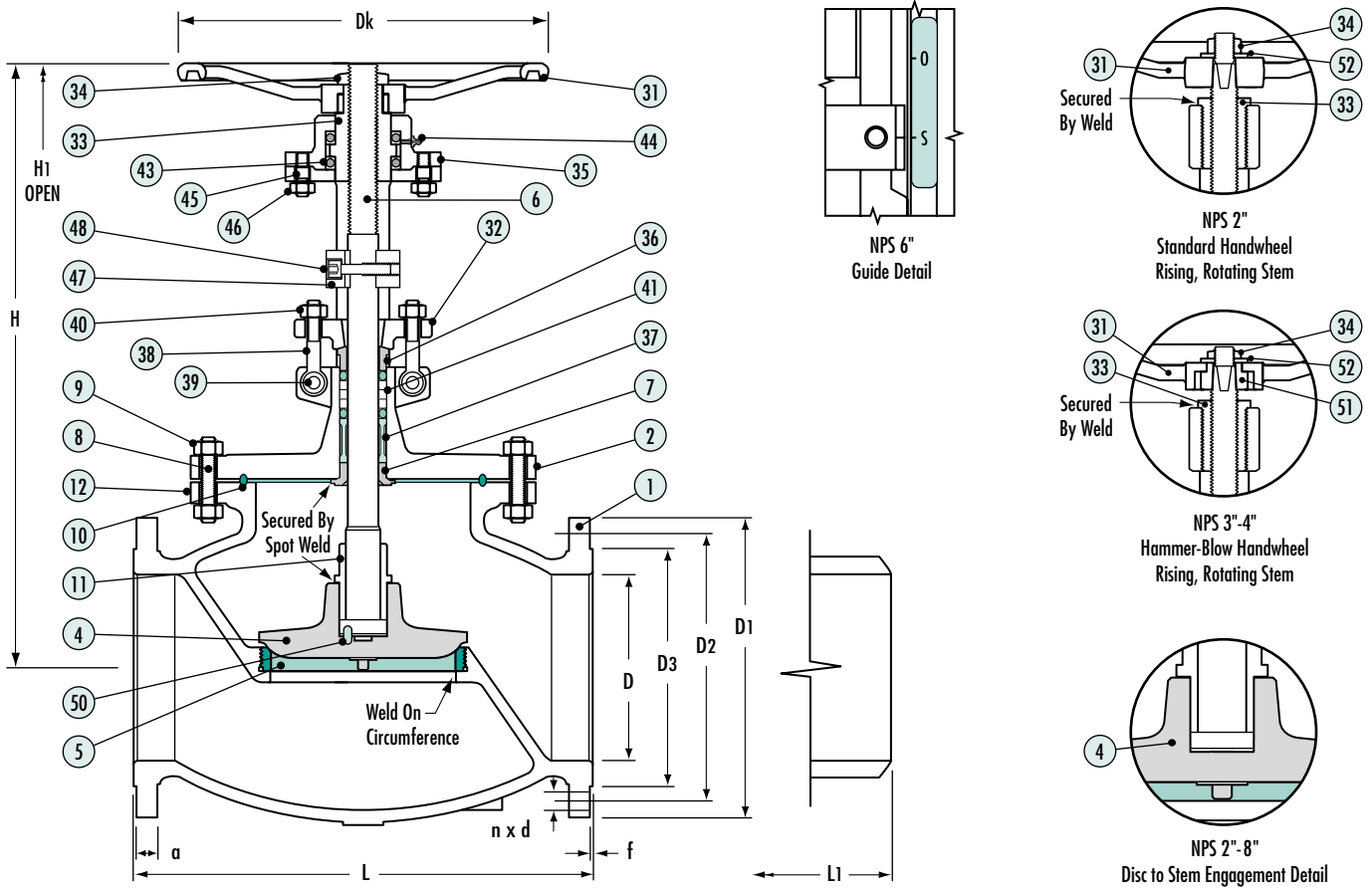

Dimensional Data (in.) and Flow Coefficient (Cv)

Size	End Flange									L	L1	H	H1(open)	Dk	Wt. Lbs.	Cv
	D	D1	Bolt Hole			D3	a	f								
			D2	n	d											
2	2.00	6.50	5.00	8	0.75	3.62	1.30	0.25	11.50	11.50	16.93	18.50	15.75	95	46.2	
2 1/2	2.50	7.50	5.87	8	0.87	4.13	1.14	0.25	13.00	13.00	20.27	22.25	17.72	163	73.2	
3	3.00	8.25	6.63	8	0.87	5.00	1.54	0.25	14.00	14.00	20.28	22.25	17.72	163	103.9	
4	4.00	10.75	8.50	8	0.98	6.18	1.81	0.25	17.00	17.00	23.23	25.59	17.72	309	189.7	
6	6.00	14.00	11.50	12	1.10	8.50	2.17	0.25	22.00	22.00	34.45	37.21	27.95	789	394.5	
8	7.88	16.50	13.75	12	1.25	10.62	2.19	0.25	26.00	26.00	28.39	31.54	22.05	800	795.8	

Contact your DSI® salesperson for Class 900 and 1500 Dimensional Data.

Swing Check Valves

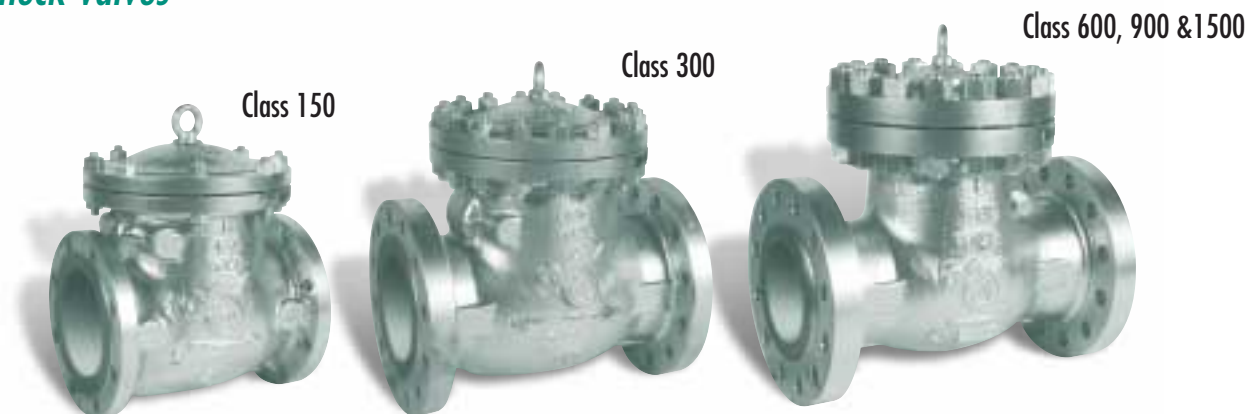

Parts And Materials • Class 150, 300, 600, 900 & 1500

Item	Part Name	WCB	LCC	C5	C12	WC6	CF8M
1	Body	A216 WCB	A352 LCC	A217 C5	A217 C12	A217 WC6	A351 CF8M
2	Cover	A216 WCB	A352 LCC	A217 C5	A217 C12	A217 WC6	A351 CF8M
3	Disc 2"-4"	A276 410T	A182 F316	A182 F9/Stellite®	A276 410T	A276 410T	A351 CF8M
	Disc 6"-24"	A216 WCB/13Cr	A352 LCC/F316	A217 C5/Stellite®	A217C12/13Cr	A217 WC6/13Cr	A351 CF8M
4	Arm	A216 WCB	A352 LCC	A217 C5	A217 C12	A217 WC6	A351 CF8M
5	Seat Ring	A105/Stellite®	A350LF2/Stellite®	A335-P5/Stellite®	AISI 321/Stellite®	A335-P5/Stellite®	A351 CF8M
6	Arm Pin	A182 F6a	A182 F316	A182 F6a	A182 F6a	A182 F6a	A479 316
8	Disc Nut	A182 F316	A182 F316	A182 F6a	A182 F6a	A182 F6a	A193 B8M
10	Gasket Cl. 150	Spiral Wound Graphite					Graphite Sheet
	Gasket Cl. 300	Spiral Wound Graphite					Spiral Wound
	Gasket Cl. 600 & above	RTJ					Spiral Wound
11	Studs	A193 B7	A320 L7M	A193 B7	A193 B7	A193 B7	A193 B8
12	Stud Nuts	A194 2H	A194 7M	A194 2H	A194 2H	A194 2H	A194 8
13	Side Plug	CSN 417041	A182 F6a	A182 F6a	A182 F6a	A182 F6a	A479 316
14	Split Pin	AISI 304	AISI 304	AISI 304	AISI 304	AISI 304	A580 316
16	Side Plug Gasket	A182 F316	A182 F316	A182 F316	A182 F316	A182 F316	A479 316
17	Nameplate	AISI 304	AISI 304	AISI 304	AISI 304	AISI 304	SS
18	Disc Sleeve	AISI 420	AISI 420	AISI 420	AISI 420	AISI 420	—
19	Arm Sleeve	AISI 420	AISI 420	AISI 420	AISI 420	AISI 420	—
20	Eyebolt	ASTM A105	ASTM A105	ASTM A105	ASTM A105	ASTM A105	—

Contact your DSI® salesperson for more information.



Class 150 Swing Check Valves (137-137 1/2)

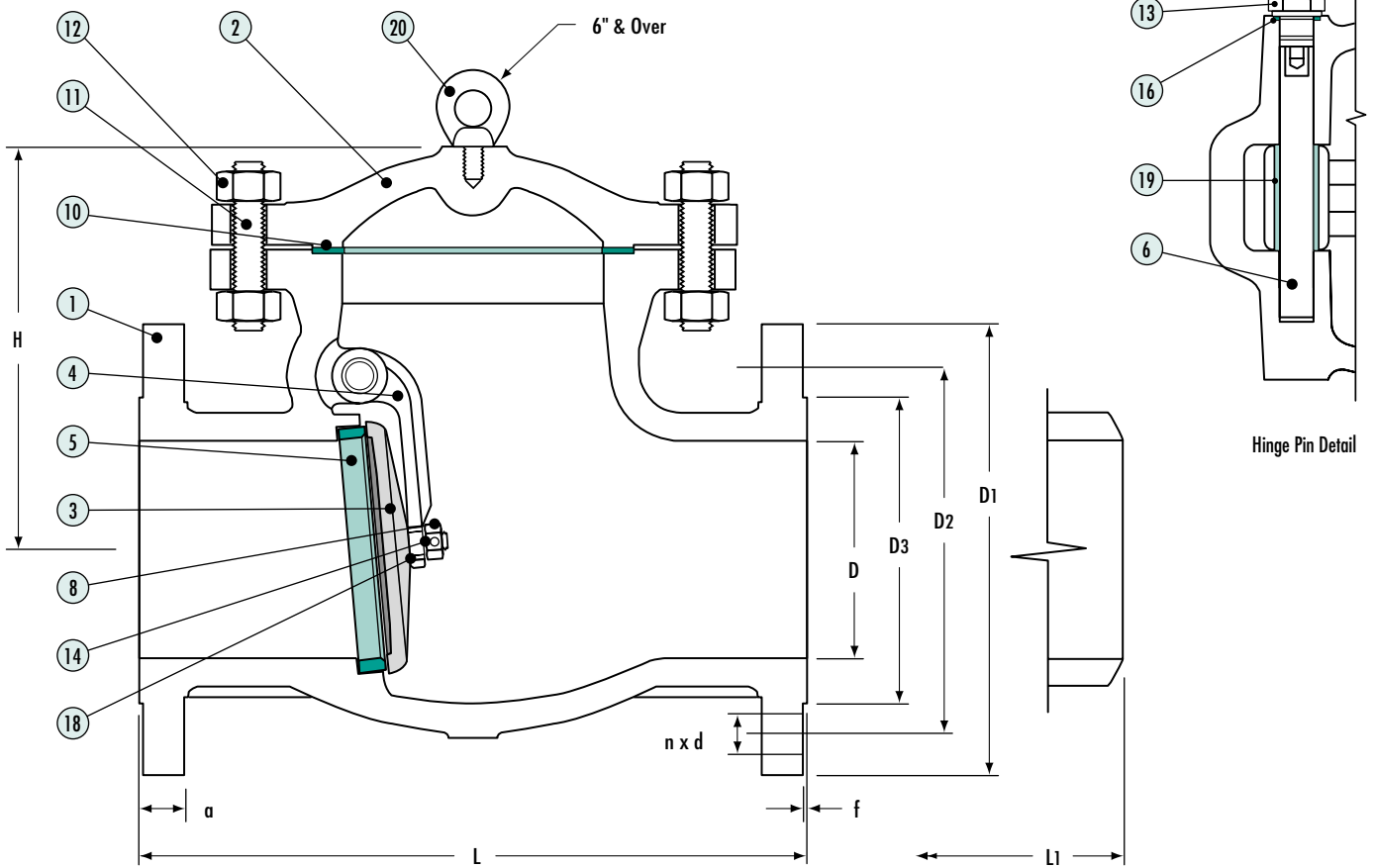

Dimensional Data (in.) and Flow Coefficient (Cv)

Size	End Flange												Wt. Lbs.	Cv
	D	D1	Bolt Hole			D3	a	f	L	L1	H			
			D2	n	d									
2	2.00	6.00	4.75	4	0.75	3.62	0.63	0.06	8.00	8.00	6.30	32	218.1	
3	3.00	7.50	6.00	4	0.75	5.00	0.75	0.06	9.50	9.50	8.27	54	499.2	
4	4.00	9.00	7.50	8	0.75	6.18	0.94	0.06	11.50	11.50	8.46	97	903.2	
6	6.00	11.00	9.50	8	0.87	8.50	1.02	0.06	14.00	14.00	10.43	155	2032.1	
8	8.00	13.50	11.75	8	0.87	10.63	1.14	0.06	19.50	19.50	12.28	245	3679	
10	10.00	16.00	14.25	12	0.98	12.75	1.22	0.06	24.50	24.50	13.86	481	5857.9	
12	12.00	19.00	17.00	12	0.98	15.00	1.26	0.06	27.50	27.50	15.83	593	8435.4	
14	13.25	21.00	18.75	12	1.10	16.25	1.38	0.06	31.00	31.00	15.94	776	11708.8	
16	15.25	23.50	21.25	16	1.10	18.50	1.46	0.06	34.00	34.00	17.91	1063	15293.2	
18	17.25	25.00	22.75	16	1.26	21.00	1.57	0.06	38.50	38.50	19.69	1265	19754.5	
20	19.25	27.50	25.00	20	1.26	23.00	1.69	0.06	38.50	38.50	20.69	1553	24912.9	
24	23.25	32.00	29.50	20	1.38	27.25	1.89	0.06	51.00	51.00	25.59	2381	36680.8	

Class 300 Swing Check Valves

(149-149 1/2)

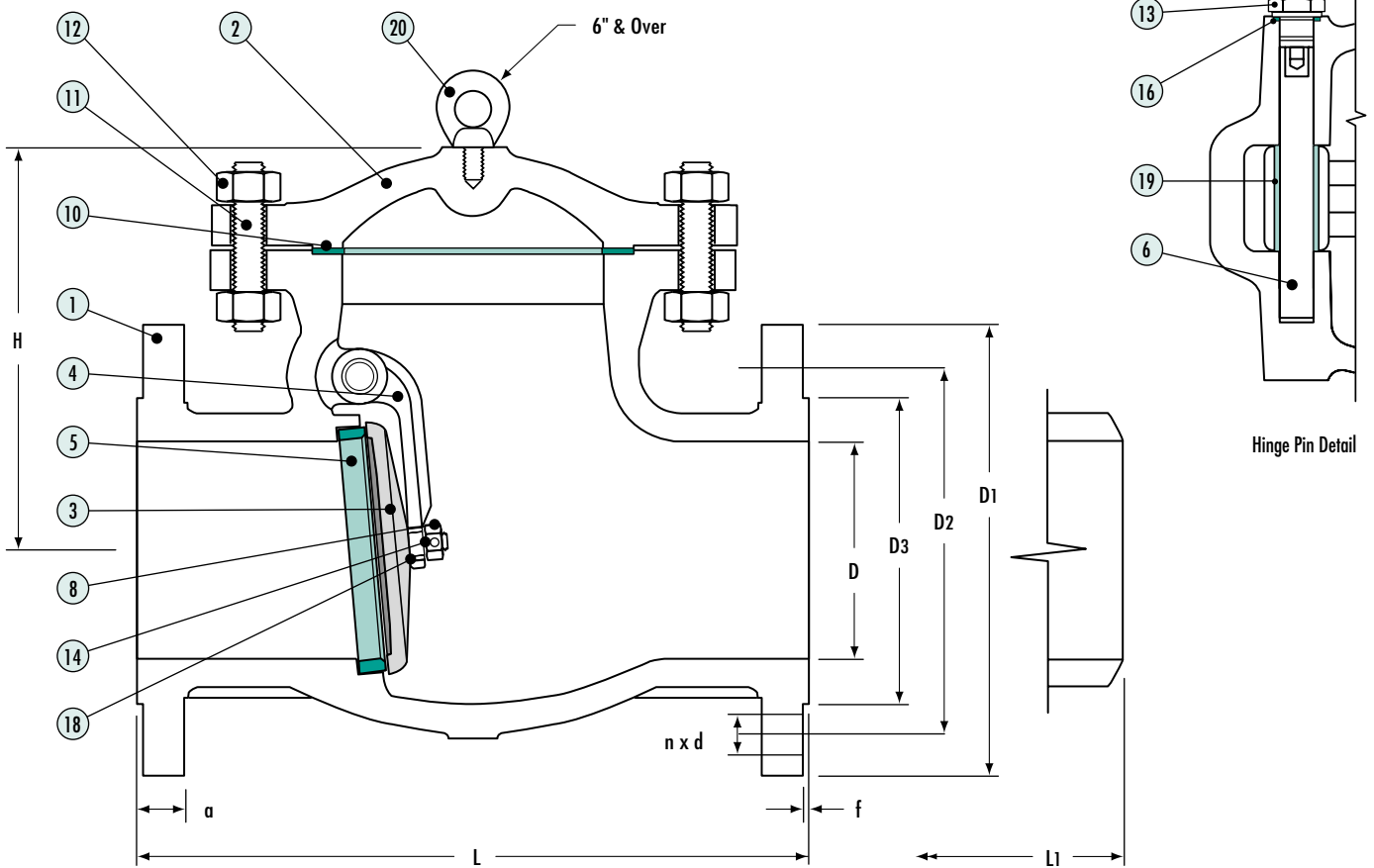

Dimensional Data (in.) and Flow Coefficient (Cv)

End Flange

Size	D	D1	Bolt Hole			D3	a	f	L	L1	H	Wt. Lbs.	Cv
			D2	n	d								
2	2.00	6.50	5.00	8	0.75	3.62	0.88	0.06	10.50	10.50	6.29	42	211.2
2 1/2	2.50	7.50	5.88	8	0.88	4.12	1.00	0.06	11.50	11.50	7.08	66	330
3	3.00	8.25	6.62	8	0.88	5.00	1.12	0.06	12.50	12.50	8.26	83	482.8
4	4.00	10.00	7.88	8	0.88	6.19	1.25	0.06	14.00	14.00	8.86	129	858.4
6	6.00	12.50	10.62	12	0.88	8.50	1.44	0.06	17.50	17.50	11.81	217	1963.2
8	8.00	15.00	13.00	12	1.00	10.62	1.62	0.06	21.00	21.00	13.07	400	3549.8
10	10.00	17.50	15.25	16	1.12	12.75	1.88	0.06	24.50	24.50	15.04	598	5546.6
12	12.00	20.50	17.75	16	1.25	15.00	2.00	0.06	28.00	28.00	17.79	851	8128.5
14	13.25	23.00	20.25	20	1.25	16.25	2.12	0.06	33.00	33.00	17.60	1023	11063.8
16	15.25	25.50	22.50	20	1.38	18.50	2.25	0.06	34.00	34.00	21.26	1705	14715.9
18	17.00	28.00	24.75	24	1.38	21.00	2.38	0.06	38.50	38.50	23.23	1771	18624.8
20	19.00	30.50	27.00	24	1.38	23.00	2.50	0.06	40.00	40.00	25.19	2761	23431.5
24	23.00	36.00	32.00	24	1.62	27.25	2.75	0.06	53.00	53.00	36.29	4184	33741.4





Class 600 Swing Check Valves (165-165 1/2)

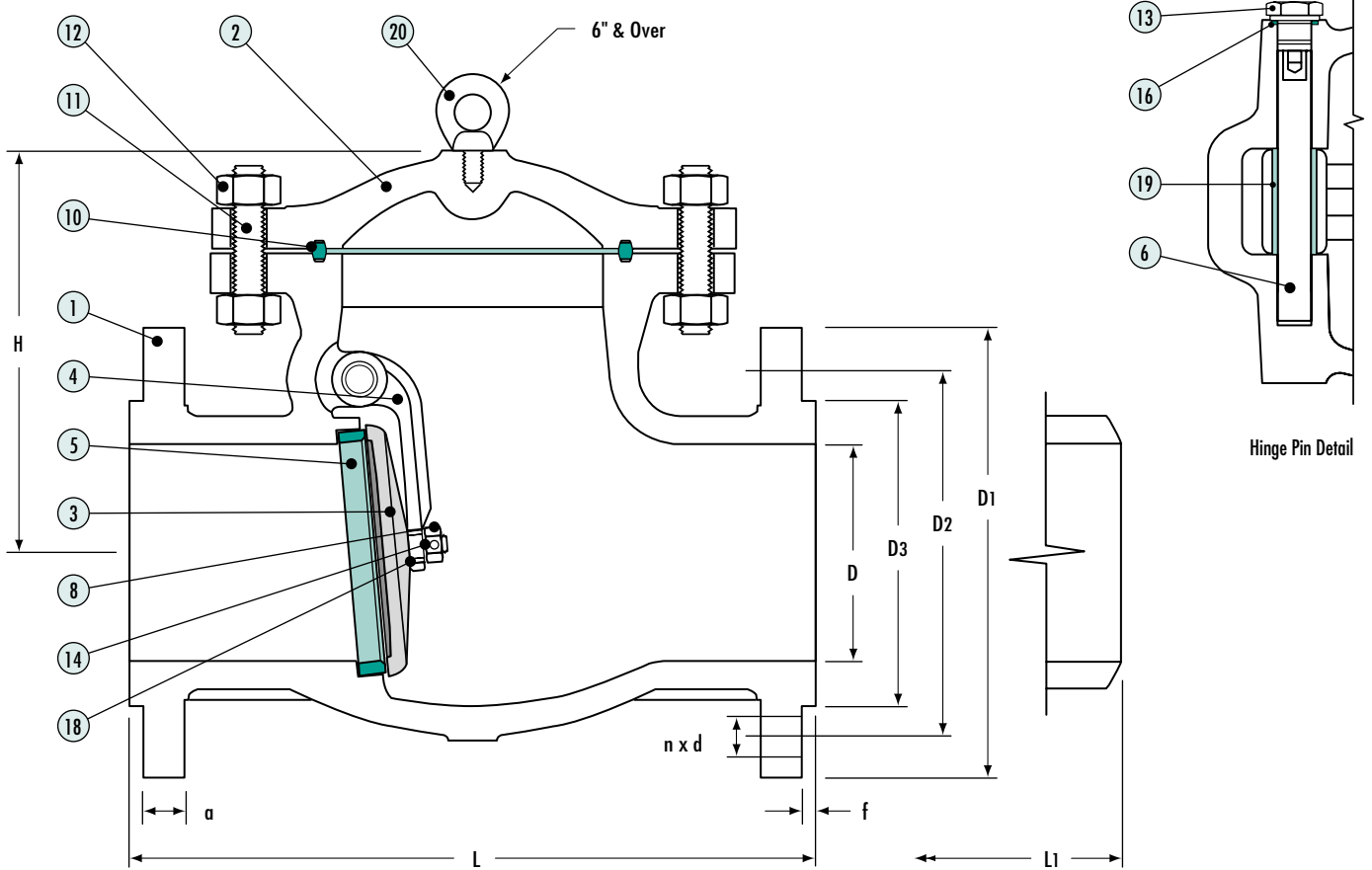

Dimensional Data (in.) and Flow Coefficient (Cv)

Size	End Flange												
	D	D1	Bolt Hole			D3	a	f	L	L1	H	Wt. Lbs.	Cv
			D2	n	d								
2	2.00	6.50	5.00	8	0.75	3.62	1.30	0.28	11.50	11.50	7.68	62	204.9
3	3.00	8.25	6.63	8	0.87	5.00	1.54	0.28	14.00	14.00	9.45	108	468
4	4.00	10.75	8.50	8	0.98	6.18	1.81	0.28	17.00	17.00	10.83	208	844.8
6	6.00	14.00	11.50	12	1.10	8.50	2.17	0.28	22.00	22.00	12.20	529	1900.9
8	7.87	16.50	13.75	12	1.26	10.63	2.48	0.28	26.00	26.00	14.57	743	3433.4
10	9.75	20.00	17.00	16	1.38	12.75	2.80	0.28	31.00	31.00	16.77	1296	5364.7
12	11.75	22.00	19.25	20	1.38	15.00	2.91	0.28	33.00	33.00	19.88	1649	7852.9
14	12.87	23.78	20.75	20	1.50	16.25	3.03	0.28	35.00	35.00	22.05	2013	10688.6
16	14.75	27.00	23.75	20	1.61	18.50	3.31	0.28	39.00	39.00	25.59	2260	14199.3

Contact your DSI® salesperson for Class 900 and 1500 Dimensional Data.

DSI® Cast Steel Valves Pressure Temperature Ratings

Pressure temperature ratings are based on ANSI/ASME B16.34 (1996 edition).

The temperatures shown are that of the pressure-containing shell, which is considered to be the same temperature as that of the fluid flowing within it.

Special consideration should be given to such items as trim, bonnet gasket material, and packing to assure that the rating is merited in all respects.

Maximum Allowable Non-Shock Pressure (PSIG)

Service Temperature		Class 150						Class 300						Class 600					Class 900	Class 1500	Class 2500		
°F	°C	WCB (a)	LCC (b)	WC6 (c,d)	C5 (d)	C12 (d)	CF8M (f)	WCB (a)	LCC (b)	WC6 (c,d)	C5 (d)	C12 (d)	CF8M (f)	WCB (a)	LCC (b)	WC6 (c,d)	C5 (d)	C12 (d)	WCB (a)	WCB (a)	WCB (a)		
-20 to 100	-29 to 38	285	290	290	290	290	275	740	750	750	750	750	720	1480	1500	1500	1500	1500	2220	3705	6170		
200	93	260	260	260	260	260	235	675	750	750	745	750	620	1350	1500	1500	1490	1500	2025	3375	5625		
300	149	230	230	230	230	230	215	655	730	720	715	730	560	1315	1455	1445	1430	1455	1970	3280	5470		
400	204	200	200	200	200	200	195	635	705	695	705	705	515	1270	1410	1385	1410	1410	1900	3170	5280		
500	260	170	170	170	170	170	170	600	665	665	665	665	480	1200	1330	1330	1330	1330	1795	2995	4990		
600	316	140	140	140	140	140	140	550	605	605	605	605	450	1095	1210	1210	1210	1210	1640	2735	4560		
650	343	125	125	125	125	125	125	535	590	590	590	590	445	1075	1175	1175	1175	1175	1610	2685	4475		
700	371	110	110	110	110	110	110	535	570	570	570	570	430	1065	1135	1135	1135	1135	1600	2665	4440		
750	399	95	95	95	95	95	95	505	505	530	530	530	425	1010	1010	1065	1055	1065	1510	2520	4200		
800	427	80	80	80	80	80	80	410	410	510	510	510	420	825	825	1015	1015	1015	1235	2060	3430		
850	454	65	65	65	65	65	65	270	270	485	485	485	420	535	535	975	965	975	805	1340	2230		
900	482	50	50	50	50	50	50	170	170	450	370	450	415	345	345	900	740	900	515	860	1430		
950	510	35	35	35	35	35	35	105	105	320	275	370	385	205	205	640	550	755	310	515	860		
1000	538	20	20	20	20	20	20	50	50	215	200	290	350	105	105	430	400	505	155	260	430		
1050	566	–	–	20(e)	20(e)	20(e)	20(e)	–	–	145	145	190	345	–	–	290	290	345	–	–	–		
1100	593	–	–	20(e)	20(e)	20(e)	20(e)	–	–	95	100	115	305	–	–	190	200	225	–	–	–		
1150	621	–	–	20(e)	20(e)	20(e)	20(e)	–	–	60	60	75	235	–	–	125	125	150	–	–	–		
1200	649	–	–	15(e)	15(e)	20(e)	20(e)	–	–	40	35	50	185	–	–	75	70	105	–	–	–		
Hydrostatic Shell Test Press.		450						1125						2225		2250					3350	5575	
Valve Closure	Liquid	315	320					815	825					1630		1650					2450	4080	
Test Pressure	Air	80						80						80					80	80			

Notes:

- (a) Permissible, but not recommended for prolonged exposure above about 800°F. Upon prolonged exposure to temperatures above about 800°F, the carbide phase of Carbon Steel may be converted to Graphite.
- (b) Not to be used over 650°F.
- (c) Not to be used over 1100°F.
- (d) Use normalized and tempered material only.
- (e) For welding end valves only. Flanged end ratings terminate at 1000°F.
- (f) At temperatures over 1000°F, use only when the Carbon content is 0.04% or higher.

For years Industry professionals have specified DSI® valve products for their most demanding projects, and consistently Zy-Tech Global Industries delivers the highest performance fluid control products available anywhere.

Ask your DSI® representative about our other fine flow control products.





Warranty And Return Policy

Warranty

For a period of (18) months from date of purchase or for a period of (12) months from date of installation of any of the goods described herein, whichever period comes first expires, ZY-TECH GLOBAL INDUSTRIES (Seller) warrants such goods shall remain free from failure due to defects in workmanship and material incorporated therein by or for ZY-TECH GLOBAL INDUSTRIES (Seller) provided such failure shall not have been caused or contributed to, by improper usage, service or application, improper installation, maintenance, repairs, alterations, or modifications effected by or for the user negligence or obligations hereunder, and provided written notification of such failure shall be immediately given to ZY-TECH GLOBAL INDUSTRIES at the following address: ZY-TECH GLOBAL INDUSTRIES, 10600 Corporate Drive, Stafford, TX 77477.

ZY-TECH GLOBAL INDUSTRIES agrees to repair, or at its sole option, to replace the goods sold at its sole expense. Apart from the warranty and undertakings of above set forth, ZY-TECH GLOBAL INDUSTRIES assumes no obligation or liability for losses, expense, or damages, direct or consequential, suffered or incurred as a result of any failure of, or defect in, the goods described herein, including but not limited to, such costs, expenses or damages as may result from the necessity to remove, replace, restore or transport the goods from any location or service in which they may be used, regardless of the cause of such failure or defect.

This warranty is the only warranty made by ZY-TECH GLOBAL INDUSTRIES in connection herewith. There are not other warranties, express or implied, of any kind given with respect to the goods, their merchantability, fitness for any particular purpose or usage, or otherwise, nor is any person authorized to extend on behalf of ZY-TECH GLOBAL INDUSTRIES any form of warranty other than that above set forth.

The goods described herein are not sold or distributed by ZY-TECH GLOBAL INDUSTRIES for personal, family or household purposes, nor are they normally suited for use as such.

Return Goods Policy

- 1) Material returned to Zy-Tech Global Industries must be accompanied with an authorized Return Goods Authorization (RGA).
- 2) Material received with proper authorization is subject to Inspection & Final Disposition by Zy-Tech Global Industries Quality Department.
- 3) Special items, buyouts, and modified products are **non-returnable**.
- 4) Returns **are not accepted** after sixty (60) days of shipment.
- 5) Standard Restocking Charge for returned materials is **15% with a \$125.00 minimum**.
- 6) Freight for material being returned to Zy-Tech Global Industries to be **prepaid**.
- 7) If clean up or re-certification is required, charges **will be deducted** from the applicable credit.
- 8) Cancellation of orders prior to shipment and/or stock transferred to a branch may incur a minimum **10% Cancellation Charge**.

Our Quality Commitment...

Zy-Tech Global Industries, Inc. is dedicated to continually improving their state-of-the-art engineering and manufacturing capabilities to improve the overall quality of their products and customer service. Zy-Tech's entire global network of flow control experts consist of highly trained technicians, engineers, and superior testing laboratories to ensure that all products supplied to our customers are 100% in accordance with industry standards as well as our own Quality Management System.



ZY-TECH GLOBAL INDUSTRIES

Note: This catalog is for reference only. All information is subject to change without notice.



Contact your local Zy-Tech representative for more information about other DSI® Brand flow control products, or visit our website at www.zy-tech.com

Your Local Representative



ZY-TECH GLOBAL INDUSTRIES

10600 Corporate Drive, Stafford, Texas 77477
(281) 565-1010 • (800) 231-3530 • Fax (281) 565-3171
sales@zy-tech.com

www.zy-tech.com

Get Connected